

Stormwater Management & Hydraulic Calculations Report

#0 Meadowbrook St. Worcester, MA 01609
Meadowbrook Definitive Subdivision & Site Plan

Prepared For:

Buckingham Development LLC
19 Cedar St.
Worcester, MA 01609

Dated: February 3, 2020

Prepared By:

Joseph Graham, PE
119 Pike St.
Tewksbury, MA 01876

Joseph Graham, PE Lic#53706
2.2.20

CONTENTS

1.0	Project Description.....	2
2.0	Background Data.....	2
3.0	Stormwater Management Standards	3
4.0	Existing Conditions Drainage Areas	10
5.0	Existing Conditions Hydrology Calculations	14
6.0	Proposed Conditions Drainage Areas	28
7.0	Proposed Conditions Hydrology Calculations.....	30
8.0	Pipe Design Calculations	261
9.0	Erosion and Sedimentation Control Plan.....	267
10.0	Long-Term Pollution Prevention and Operation & Maintenance Plan.....	271
11.0	DEP Checklist for Stormwater Report.....	273
12.0	Illicit Discharge Compliance Statement	282
	Appendices.....	284
	A. NRCS Soils Survey & Map.....	284
	B. Flood Insurance Rate Map	284
	C. USGS Quad Map.....	284
	D. TSS Removal Worksheet	284
	Attachments.....	291
	A. Site Plan Permitting sheet set.....	291
	B. SWPPP Inspection and Corrective Action Forms	291
	C. Long-Term Operation and Maintenance Log.....	291

Joseph Graham, PE, has prepared this Stormwater Management Memorandum on behalf of Buckingham Development LLC (the "Applicant"). The Applicant proposes the development of parcels 25-033-0008(0 Meadbrook St.) in Worcester, MA. (the "Property"). The Applicant proposes the construction of one (1) single family building with cul de sac and associated infrastructure on an unimproved wooded site.

This Stormwater Management Report has been prepared to recreate the original approved plan and illustrate the previously approved design meets current design requirements as the original approval was incomplete. It is the intent of this report to demonstrate compliance with the Massachusetts Department of Environmental Protection (MassDEP) Stormwater Standards and The City of Worcester Department of Public Works. More specifically, this report is provided to demonstrate that the proposed development, erosion control measures and compliance with applicable standards for stormwater management as well as the City of Worcester subdivision control rules and regulations. The site plans have been provided to illustrate the design and associated drainage and grading for the construction of the roadway, drainage and utility infrastructure and houses.

1.0 PROJECT DESCRIPTION

The Project area is comprised of an existing wooded site adjacent to existing wetlands flagged during the 2009 original submission of the definitive site plans. The plans depict the construction of a level spreader and water quality swale to mitigate the additional impervious area created during the construction of the ~8,700 SF of new impervious area. The Stormwater system proposed will exceed Stormwater guidelines under The Massachusetts Stormwater Regulations and meet standards 1 thru 9 of the regulations.

2.0 BACKGROUND DATA

The following plans & data were reviewed and used in the design of the proposed stormwater design. These references will be attached for ease of review by the board:

- Site Plan permit drawings – dated 2/2/2020
- USGS Topographical Map, Worcester South Quad
- FIRM Flood Insurance Rate Map, Worcester County
- Map Number 25027C0802E and 2555027C0804E, Effective Date July 4, 2011
- NRCS map Soil Survey Map

The U.S. Natural Resources Conservation Service (NRCS) formerly SCS Soil Survey Maps indicate that soils with hydrological soil group classification C are present on site. See the Soils map attached to this report. A soils exploration was not performed prior to this report, however a test pit can be excavated as part of the approval process to ensure proper placement of the stormwater system above the groundwater. Should groundwater elevations prove higher than anticipated the site can be raised prior to construction.

The Soils maps indicate the following:

- 305B Paxton fine sandy loam, 3 to 8 percent slopes
 - (Hydrologic Soils Group Classification – C)
- 307C Paxton fine sandy loam, 8 to 15 percent slopes, extremely stony
 - (Hydrologic Soils Group Classification – C)
- 307E Paxton fine sandy loam, 15 to 35 percent slopes, extremely stony
 - (Hydrologic Soils Group Classification – C)
- 625C Hinkley-Urban land complex, 0 to 15 percent slopes
 - (Hydrologic Soils Group Classification – A)

3.0 STORMWATER MANAGEMENT STANDARDS

3.0 INTRODUCTION

This Stormwater Management report is intended to accompany plans and computations for the Amended site plan entitled “**Meadowbrook Definitive Site Plan, Dated 2/2/2020**” see Attachment A. The site plan depicts a new subdivision roadway with buildings and associated drainage. Within this report are calculations that support a final engineering design for the stormwater management system within the proposed development. The stormwater system has been designed to meet the requirements outlined within the MA DEP Stormwater Management Handbook.

The final design intends to meet the following:

- Identify the natural drainage patterns of the proposed project area.
- Identify underlying soils conditions.
- Limit stormwater runoff rates for the 2, 10, 50 & 100-year storm events to pre-construction levels after development.
- Prevent erosion & sediment and other suspended solid contaminants by trapping them onsite with Best Management Practices.
- Provide adequate drainage for new surfaces.
- Identify the BMP’s to treat, mitigate and attenuate any increase of surface runoff generated by the proposed site development in a way to maintain the existing flow patterns.
- The Watershed contains approximately 1 acre of land. Soils present on site as shown on the NCRS Soils Survey and an on the ground soils exploration pit, show soils belonging to the hydrologic soil group B.
- Runoff has been analyzed under both pre-development and post development conditions.

3.1 UNTREATED STORMWATER (STANDARD 1)

The project is designed so that new stormwater conveyances (outfalls/ discharges) do not discharge untreated stormwater into, or cause erosion to, wetlands. Deep sump catch basins, proprietary separators and infiltration systems are proposed. As Noted in the calculations in Section 7.0 peak flow rates are predicted to decrease in the proposed system.

Standard #1 is met.

3.2 POST-DEVELOPMENT PEAK RATES (STANDARD 2)

Hydrologic calculations were performed to determine the rate of runoff for the 2, 10, 25-year storm events under pre-development (present) conditions. The City of Worcester by regulation only requires site plans to design up to the 25-year storm event. This value was established as the future (post-development) maximum allowable rate. Unmitigated post-development rates were then computed in a similar manner. It is the intent of the stormwater management system to minimize impacts to drainage patterns of downstream property and wetlands while simultaneously providing water quality treatment to runoff prior to its release from the site or discharge to wetlands.

The U.S.D.A. Soil Conservation Service (SCS) Technical Release 55 (TR-55), 1986, was used as the procedure for estimating runoff. A SCS TR-20-based computer program, "HydroCAD," was used for estimating peak discharges. TR-55 is a generally accepted model for use on small sites that begins with a rainfall amount uniformly imposed on the watershed over a specified time distribution. Mass rainfall is converted to mass runoff by using a runoff curve number (CN). CN is based on soils, ground cover, impervious areas, interception and surface storage. Runoff is then transformed into a hydrograph that depends on runoff travel time through segments of the watershed. Development in a watershed changes its response to precipitation. The most common effects are reduced infiltration and decreased travel time, which result in significantly higher peak rates of runoff. The volume of runoff is determined primarily by the amount of precipitation and by infiltration characteristics related to soil type, antecedent rainfall, and type of vegetative cover, impervious surfaces, and surface retention. Travel time is determined primarily by slope, flow length, and depth of flow surfaces. Peak rates of discharge are based on the relationship of the above parameters as well as the total drainage area of the watershed, the location of the development in relation to the total drainage area, and the effect of any flood control works or other manmade storage. Peak rates of discharge are also influenced by the distribution of rainfall within a given storm event.

Stormwater management computations for the project site were performed using SCS-based HydroCAD for existing and proposed conditions, curve numbers, time of concentration and unit hydrograph computations

3.2.1 Existing Conditions

Under the pre-construction scenario, the existing watershed is one large area referred to as SUBCATCHMENT 1S and running towards the northern end of property. The runoff slopes dramatically across the front portion and gradual along the rear of the parcel to Design Point (DP1), at the corner of the parcel as shown on the site plan (Section 4.0). Currently, stormwater is uncontrolled as the site is not developed. The ± 47,500 square feet of undeveloped site consists mainly of undeveloped stony woods at moderate to steep slopes.

3.2.2 Proposed Conditions

Under post-construction conditions the existing watershed on the site will be maintained with peak flows attenuated for post-construction development. The site is divided into four (4) subcatchments including a subcatchment for the roof of the proposed building. A dry infiltration swale with a sediment forebay was designed to attenuate stormwater runoff from surface flow of the paved areas and the landscaped grading from

house lot. The swale will be constructed to infiltrate flow from this area to recharge the groundwater, see Section 6.0. There was one (1) Design point for the proposed condition.

- DP1 is the portion of runoff that will be directed into the proposed infiltration swale as well as the portion of runoff from the site that will be controlled via grading.
- Subcatchment 1P is a portion of the site of roadway runoff directed to Catch Basin #1.
- Subcatchment 2P is the portion of the site directed to Catch Basin #2.
- Subcatchment 3P is the area associated with the proposed single family building.
- Subcatchment 4P is the portion of the site associated with the site grading directed to DP1.

As summarized in Tables 3.1 and 3.2 below, the unretained runoff decreases in Post Construction. Comparison should be made between Design Point 1 (DP1) for both Existing and the Proposed. Stormwater entering the municipal stormwater system increases slightly but down gradient capacity can handle the increase in the 25-year storm.

Table 3.1 Summary of construction Runoff (cfs)

Design Point	2-year	10-year	25-year	100-year
DP1 (Pre)	0.46	1.52	2.15	3.38
DP1 (Post)	0.46	1.33	1.87	2.94

Standard #2 is met.

3.3 RECHARGE TO GROUNDWATER (STANDARD 3)

In accordance with the Massachusetts Stormwater Handbook, projects must calculate the required recharge volume using any additional impervious areas that was added to the site. The proposed impervious area of subcatchments 1 thru 4 will be used for this analysis. The loss of annual recharge to groundwater has been minimized using stormwater Best Management Practices (BMP's), a proposed infiltration basin will be used for this project. Although runoff volumes will not increase after construction; recharge shall be provided. Therefore, stormwater runoff volume to be recharged to groundwater should be determined using the existing site (pre-development) soil conditions and the annual recharge from the post-development site should approximate the annual recharge from the pre-development or existing site, based on soil types.

Hydrologic Soil Group Volume to Recharge (x Total Impervious Area)

<u>NRCS Hydrologic Soil</u> <u>Group(HSG)</u>	<u>Target Depth Factor (F)</u>	<u>Project Sq. Ft per HSG*</u>
--	--------------------------------	--------------------------------

A	0.60 inches of runoff	0
B	0.35 inches of runoff	45,539
C	0.25 inches of runoff	0
D	0.10 inches of runoff	0

1. Recharge Volume Required (Rv_{req.})

0.60 inches x (1ft. /12in.) x (0) sq. ft. = 0 cubic feet
 0.35 inches x (1ft. /12in.) x (45,539) sq. ft. = 1,328 cubic feet
 0.25 inches x (1ft. /12in.) x (0) sq. ft. = 0 cubic ft
 0.10 inches x (1ft. /12in.) x (0) sq. ft. = 0 cubic feet

Rv_{req.} = 1,328 cu. ft

2. Recharge Volume Provided (Rv_{prov.})

(swale) = 1,368 cu. Ft
 (INF-1) = 120 cu. Ft

Rv_{prov.} = 1,488 cu. ft.

As shown in the above calculations the recharge volume provided exceeds the amount required per the Massachusetts Stormwater Handbook. 1,488 cu. ft. – 1,328 cu. ft. = 160 cu. ft. ✓

Drawdown Time

The current regulations require that an infiltration BMP will drain within 72 hours. To determine whether the proposed basin will drain within 72 hours, the following formula must be used:

$$\text{Time (drawdown)} = \frac{Rv}{(K)(\text{bottom area})}$$

Where: Rv = Required Recharge Volume, calculated above

K = Saturated Hydraulic Conductivity for “Static” and “Simple Dynamic” Methods. Use Rawls rate of 2.41 will be used. See Table 2.3.3 of Volume 3: Massachusetts Stormwater Management standards for Rawls Rates of NRCS soil groups

B = Bottom area of the recharge structure.

Proposed Infiltration system:

$$\text{INF-1: } 120 \text{ c.f.} / (0.35 \text{ in/hr}) (1 \text{ ft}/12 \text{ in.}) (80 \text{ s.f.}) = 51 \text{ hours} * \checkmark$$

$$\text{Swale: } 1,368 \text{ c.f.} / (0.35 \text{ in/hr}) (1 \text{ ft}/12 \text{ in.}) (658 \text{ s.f.}) = 71 \text{ hours} * \checkmark$$

Standard #3 is met.

3.4 REMOVAL OF 80% TSS (STANDARD 4)

Stormwater management systems shall be designed to remove 80% of the average annual post-construction load of Total Suspended Solids(TSS). This standard is met with pollution prevent plans (see Section 9.0), Stormwater BMP's sized to capture required water quality volume (see below), and pretreatment measures.

The proposed stormwater management system has been designed to remove a minimum of 80% of the average annual post-construction load of TSS. The project proposes the installation of 4ft. hooded deep sump catchbasins to collect runoff from the site which will then be transported through a closed pipe system to a surface detention/infiltration basin. Runoff from un-developed portions of the site does not require TSS removal. Calculations for the removal rates for the developed paved (not roof) areas are shown in appendix D, the TSS Removal Calculation Worksheet.

Water Quality

$$V_{wq} = (D_{wq} / 12 \text{ inches/foot})(A_{imp})$$

Where: V_{wq} = Required Water Quality Volume (cu.ft.)

$$D_{wq} = \text{Water Quality Dept} - 1.0 \text{ inches}$$

$$A_{imp} = \text{Impervious Area (s.f.)}$$

V_{wq} required

$$0.5 \text{ inches} \times (1 \text{ ft.}/12 \text{ in.}) \times (1,368 \text{ s.f.}) = 57. \text{ cu. ft.}$$

V_{wq} Provided

Outlet orifices in the infiltration units are set at an elevation above the required water quality volume. The volume provided exceeds the requirement and is as follows:

$$\underline{\text{PROPOSED LEVEL SPREADER}} = 70 \text{ cu. Ft.}$$

Total V_{wq} Provided = 70 cu.ft. > 57 cu.ft. ✓

Standard #4 is met.

3.5 LAND USES WITH HIGHER POTENTIAL POLLUTANT LOADS (STANDARD 5)

Stormwater Standard 5 is not applicable to this project. This proposed development will not subject the site to a higher potential pollutant load as defined in the Massachusetts Department of Environmental Protection Wetlands and Water Quality Regulations.

Standard #5 is met.

3.6 CRITICAL AREAS (STANDARD 6)

This site is considered a critical area as defined by MassDEP's Massachusetts Stormwater Handbook. To comply with the Massachusetts Stormwater Regulation 44%TSS removal will be provided prior to stormwater runoff entering the infiltration basin. This will be accomplished using Contech 450i Stormceptor installed prior to stormwater entering the infiltration basin. See attached TSS removal worksheet for compliance.

Standard #6 is met.

3.7 REDEVELOPMENT (STANDARD 7)

The site is not a redevelopment project as defined by the MassDEP's Massachusetts Stormwater Handbook. The intent of this stormwater report is to amend the previously approved report accounting for the development of the entire site.

Standard #7 is met.

3.8 EROSION & SEDIMENTATION CONTROL (STANDARD 8)

An Operation and Maintenance & Erosion and Sediment Control Program for the proposed Stormwater Management System is included as part of this report. Please see Section 9.0. The

program details the construction period operation and maintenance plan and sequencing for pollution prevention measures and erosion and sediment controls. Locations of erosions control measures for the project are depicted on the site plan set accompanying this report.

Standard #8 is met

3.9 OPERATION & MAINTENANCE PLAN (STANDARD 9)

An Operation & Maintenance Plan is included as part of this report. Please see Section 10.0 This appendix provides details and schedule for routine and non-routine maintenance tasks to be implemented at the completion of the project.

Standard #9 is met

3.10 ILLICIT DISCHARGES (STANDARD 10)

There shall be no illicit discharges to the stormwater management system. During construction and post construction procedures are provided to dissipate the potential for illicit discharges to the drainage system. Post construction preventions of illicit discharges are described in the Long-Term Operations and Maintenance Program under the Good Housekeeping See Section 10.10 of this report.

Standard #10 is met

3.11 SUMMARY

The Stormwater Management Plan present herein and as shown on the Site Plans, included as Attachment A, have been prepared in accordance with the applicable local, state, and federal regulations. The design employs Best Management Practices for maintaining stormwater runoff quality both during and after construction and is designed to protect downstream and underlying receiving waters from stormwater related impacts. The proposed stormwater system has been designed such that the post-development conditions do not increase the peak runoff rates for the 2-year, 10-year, 25-year and 100-year, 24-hour storm events predominately through the careful site grading and routing to infiltration systems. The above table 3.1 summarizes the design achievements.

5.0 EXISTING CONDITIONS HYDROLOGY CALCULATIONS

HydroCAD Printouts

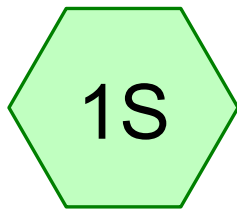

UNDEVELOPED SITE

DESIGN POINT

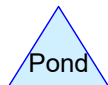
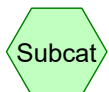

18134 - EC SITE*Type III 24-hr 2-yr Storm Rainfall=3.00"*

Prepared by {enter your company name here}

Page 2

HydroCAD® 7.10 s/n 002940 © 2005 HydroCAD Software Solutions LLC

2/3/2020

Time span=5.00-20.00 hrs, dt=0.05 hrs, 301 points

Runoff by SCS TR-20 method, UH=SCS

Reach routing by Stor-Ind+Trans method - Pond routing by Stor-Ind method

Subcatchment 1S: UNDEVELOPED SITE

Runoff Area=45,539 sf Runoff Depth>0.45"

Flow Length=340' Tc=5.2 min CN=65 Runoff=0.46 cfs 0.039 af

Link DP1: DESIGN POINT

Inflow=0.46 cfs 0.039 af

Primary=0.46 cfs 0.039 af

18134 - EC SITE

Type III 24-hr 2-yr Storm Rainfall=3.00"

Prepared by {enter your company name here}

Page 3

HydroCAD® 7.10 s/n 002940 © 2005 HydroCAD Software Solutions LLC

2/3/2020

Subcatchment 1S: UNDEVELOPED SITE

Runoff = 0.46 cfs @ 12.11 hrs, Volume= 0.039 af, Depth> 0.45"

Runoff by SCS TR-20 method, UH=SCS, Time Span= 5.00-20.00 hrs, dt= 0.05 hrs
Type III 24-hr 2-yr Storm Rainfall=3.00"

Area (sf)	CN	Description
38,859	65	Woods/grass comb., Fair, HSG B
6,680	65	Woods/grass comb., Fair, HSG B
45,539	65	Weighted Average

Tc (min)	Length (feet)	Slope (ft/ft)	Velocity (ft/sec)	Capacity (cfs)	Description
0.5	60	0.1500	1.9		Shallow Concentrated Flow, STEEPER OVERLAND FLOW Woodland Kv= 5.0 fps
4.7	280	0.0400	1.0		Shallow Concentrated Flow, OVERLAND FLOW Woodland Kv= 5.0 fps
5.2	340	Total			

Link DP1: DESIGN POINT

Inflow Area = 1.045 ac, Inflow Depth > 0.45" for 2-yr Storm event

Inflow = 0.46 cfs @ 12.11 hrs, Volume= 0.039 af

Primary = 0.46 cfs @ 12.11 hrs, Volume= 0.039 af, Atten= 0%, Lag= 0.0 min

Primary outflow = Inflow, Time Span= 5.00-20.00 hrs, dt= 0.05 hrs

18134 - EC SITE*Type III 24-hr 10-yr Storm Rainfall=4.50"*

Prepared by {enter your company name here}

Page 4

HydroCAD® 7.10 s/n 002940 © 2005 HydroCAD Software Solutions LLC

2/3/2020

Time span=5.00-20.00 hrs, dt=0.05 hrs, 301 points

Runoff by SCS TR-20 method, UH=SCS

Reach routing by Stor-Ind+Trans method - Pond routing by Stor-Ind method

Subcatchment 1S: UNDEVELOPED SITE

Runoff Area=45,539 sf Runoff Depth>1.21"

Flow Length=340' Tc=5.2 min CN=65 Runoff=1.52 cfs 0.105 af

Link DP1: DESIGN POINT

Inflow=1.52 cfs 0.105 af

Primary=1.52 cfs 0.105 af

18134 - EC SITE

Type III 24-hr 10-yr Storm Rainfall=4.50"

Prepared by {enter your company name here}

Page 5

HydroCAD® 7.10 s/n 002940 © 2005 HydroCAD Software Solutions LLC

2/3/2020

Subcatchment 1S: UNDEVELOPED SITE

Runoff = 1.52 cfs @ 12.09 hrs, Volume= 0.105 af, Depth> 1.21"

Runoff by SCS TR-20 method, UH=SCS, Time Span= 5.00-20.00 hrs, dt= 0.05 hrs
Type III 24-hr 10-yr Storm Rainfall=4.50"

Area (sf)	CN	Description
38,859	65	Woods/grass comb., Fair, HSG B
6,680	65	Woods/grass comb., Fair, HSG B
45,539	65	Weighted Average

Tc (min)	Length (feet)	Slope (ft/ft)	Velocity (ft/sec)	Capacity (cfs)	Description
0.5	60	0.1500	1.9		Shallow Concentrated Flow, STEEPER OVERLAND FLOW Woodland Kv= 5.0 fps
4.7	280	0.0400	1.0		Shallow Concentrated Flow, OVERLAND FLOW Woodland Kv= 5.0 fps
5.2	340	Total			

Link DP1: DESIGN POINT

Inflow Area = 1.045 ac, Inflow Depth > 1.21" for 10-yr Storm event
 Inflow = 1.52 cfs @ 12.09 hrs, Volume= 0.105 af
 Primary = 1.52 cfs @ 12.09 hrs, Volume= 0.105 af, Atten= 0%, Lag= 0.0 min

Primary outflow = Inflow, Time Span= 5.00-20.00 hrs, dt= 0.05 hrs

18134 - EC SITE*Type III 24-hr 25-yr Storm Rainfall=5.25"*

Prepared by {enter your company name here}

Page 6

HydroCAD® 7.10 s/n 002940 © 2005 HydroCAD Software Solutions LLC

2/3/2020

Time span=5.00-20.00 hrs, dt=0.05 hrs, 301 points

Runoff by SCS TR-20 method, UH=SCS

Reach routing by Stor-Ind+Trans method - Pond routing by Stor-Ind method

Subcatchment 1S: UNDEVELOPED SITE

Runoff Area=45,539 sf Runoff Depth>1.67"

Flow Length=340' Tc=5.2 min CN=65 Runoff=2.15 cfs 0.145 af

Link DP1: DESIGN POINT

Inflow=2.15 cfs 0.145 af

Primary=2.15 cfs 0.145 af

18134 - EC SITE

Type III 24-hr 25-yr Storm Rainfall=5.25"

Prepared by {enter your company name here}

Page 7

HydroCAD® 7.10 s/n 002940 © 2005 HydroCAD Software Solutions LLC

2/3/2020

Subcatchment 1S: UNDEVELOPED SITE

Runoff = 2.15 cfs @ 12.09 hrs, Volume= 0.145 af, Depth> 1.67"

Runoff by SCS TR-20 method, UH=SCS, Time Span= 5.00-20.00 hrs, dt= 0.05 hrs
Type III 24-hr 25-yr Storm Rainfall=5.25"

Area (sf)	CN	Description
38,859	65	Woods/grass comb., Fair, HSG B
6,680	65	Woods/grass comb., Fair, HSG B
45,539	65	Weighted Average

Tc (min)	Length (feet)	Slope (ft/ft)	Velocity (ft/sec)	Capacity (cfs)	Description
0.5	60	0.1500	1.9		Shallow Concentrated Flow, STEEPER OVERLAND FLOW Woodland Kv= 5.0 fps
4.7	280	0.0400	1.0		Shallow Concentrated Flow, OVERLAND FLOW Woodland Kv= 5.0 fps
5.2	340	Total			

Link DP1: DESIGN POINT

Inflow Area = 1.045 ac, Inflow Depth > 1.67" for 25-yr Storm event

Inflow = 2.15 cfs @ 12.09 hrs, Volume= 0.145 af

Primary = 2.15 cfs @ 12.09 hrs, Volume= 0.145 af, Atten= 0%, Lag= 0.0 min

Primary outflow = Inflow, Time Span= 5.00-20.00 hrs, dt= 0.05 hrs

18134 - EC SITE*Type III 24-hr 100-yr Storm Rainfall=6.60"*

Prepared by {enter your company name here}

Page 8

HydroCAD® 7.10 s/n 002940 © 2005 HydroCAD Software Solutions LLC

2/3/2020

Time span=5.00-20.00 hrs, dt=0.05 hrs, 301 points

Runoff by SCS TR-20 method, UH=SCS

Reach routing by Stor-Ind+Trans method - Pond routing by Stor-Ind method

Subcatchment 1S: UNDEVELOPED SITE

Runoff Area=45,539 sf Runoff Depth>2.58"

Flow Length=340' Tc=5.2 min CN=65 Runoff=3.38 cfs 0.225 af

Link DP1: DESIGN POINT

Inflow=3.38 cfs 0.225 af

Primary=3.38 cfs 0.225 af

18134 - EC SITE

Type III 24-hr 100-yr Storm Rainfall=6.60"

Prepared by {enter your company name here}

Page 9

HydroCAD® 7.10 s/n 002940 © 2005 HydroCAD Software Solutions LLC

2/3/2020

Subcatchment 1S: UNDEVELOPED SITE

Runoff = 3.38 cfs @ 12.09 hrs, Volume= 0.225 af, Depth> 2.58"

Runoff by SCS TR-20 method, UH=SCS, Time Span= 5.00-20.00 hrs, dt= 0.05 hrs

Type III 24-hr 100-yr Storm Rainfall=6.60"

Area (sf)	CN	Description
38,859	65	Woods/grass comb., Fair, HSG B
6,680	65	Woods/grass comb., Fair, HSG B
45,539	65	Weighted Average

Tc (min)	Length (feet)	Slope (ft/ft)	Velocity (ft/sec)	Capacity (cfs)	Description
0.5	60	0.1500	1.9		Shallow Concentrated Flow, STEEPER OVERLAND FLOW Woodland Kv= 5.0 fps
4.7	280	0.0400	1.0		Shallow Concentrated Flow, OVERLAND FLOW Woodland Kv= 5.0 fps
5.2	340	Total			

Link DP1: DESIGN POINT

Inflow Area = 1.045 ac, Inflow Depth > 2.58" for 100-yr Storm event

Inflow = 3.38 cfs @ 12.09 hrs, Volume= 0.225 af

Primary = 3.38 cfs @ 12.09 hrs, Volume= 0.225 af, Atten= 0%, Lag= 0.0 min

Primary outflow = Inflow, Time Span= 5.00-20.00 hrs, dt= 0.05 hrs

7.0 PROPOSED CONDITIONS HYDROLOGY CALCULATIONS

HydroCAD Printouts

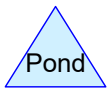
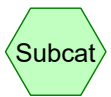
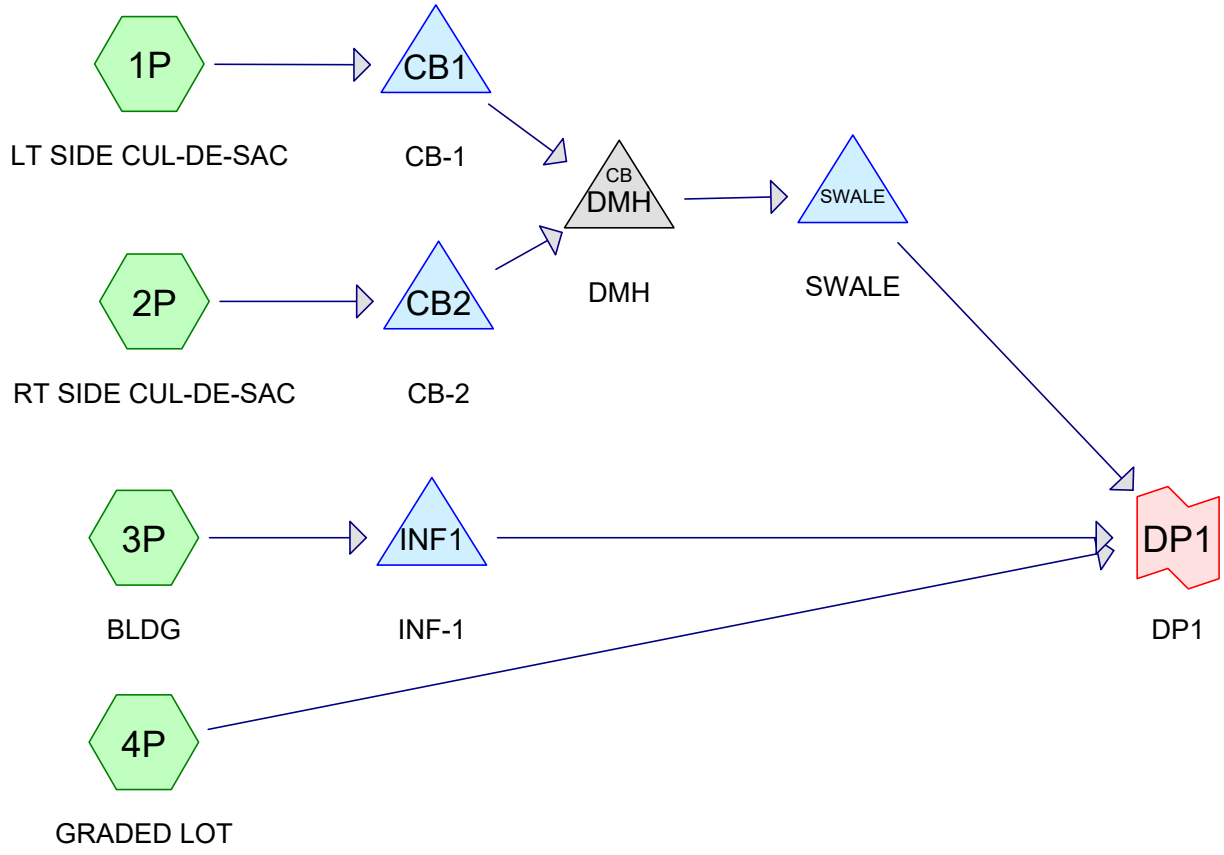

18134 - PROP SITE

Prepared by {enter your company name here}
HydroCAD® 7.10 s/n 002940 © 2005 HydroCAD Software Solutions LLC

18134-prop
Type III 24-hr 2-yr Storm Rainfall=3.00"

Page 2
2/3/2020

Time span=5.00-20.00 hrs, dt=0.05 hrs, 301 points
Runoff by SCS TR-20 method, UH=SCS
Reach routing by Stor-Ind+Trans method - Pond routing by Stor-Ind method

Subcatchment 1P: LT SIDE CUL-DE-SAC Runoff Area=4,355 sf Runoff Depth>2.59"
Flow Length=75' Tc=0.6 min CN=98 Runoff=0.33 cfs 0.022 af

Subcatchment 2P: RT SIDE CUL-DE-SAC Runoff Area=2,325 sf Runoff Depth>2.59"
Flow Length=50' Tc=0.4 min CN=98 Runoff=0.18 cfs 0.012 af

Subcatchment 3P: BLDG Runoff Area=1,600 sf Runoff Depth>2.59"
Tc=5.0 min CN=98 Runoff=0.11 cfs 0.008 af

Subcatchment 4P: GRADED LOT Runoff Area=37,259 sf Runoff Depth>0.23"
Flow Length=340' Tc=5.1 min CN=58 Runoff=0.11 cfs 0.017 af

Pond CB1: CB-1 Peak Elev=596.44' Storage=54 cf Inflow=0.33 cfs 0.022 af
Primary=0.33 cfs 0.020 af Secondary=0.00 cfs 0.000 af Outflow=0.33 cfs 0.020 af

Pond CB2: CB-2 Peak Elev=596.46' Storage=53 cf Inflow=0.18 cfs 0.012 af
Primary=0.18 cfs 0.010 af Secondary=0.00 cfs 0.000 af Outflow=0.18 cfs 0.010 af

Pond DMH: DMH Peak Elev=596.02' Inflow=0.50 cfs 0.031 af
Primary=0.50 cfs 0.031 af Secondary=0.00 cfs 0.000 af Outflow=0.50 cfs 0.031 af

Pond INF1: INF-1 Peak Elev=597.03' Storage=0.004 af Inflow=0.11 cfs 0.008 af
Discarded=0.01 cfs 0.005 af Secondary=0.00 cfs 0.000 af Outflow=0.01 cfs 0.005 af

Pond SWALE: SWALE Peak Elev=595.33' Storage=0.011 af Inflow=0.50 cfs 0.031 af
Discarded=0.02 cfs 0.013 af Primary=0.42 cfs 0.010 af Outflow=0.44 cfs 0.024 af

Link DP1: DP1 Inflow=0.46 cfs 0.027 af
Primary=0.46 cfs 0.027 af

18134 - PROP SITE

Type III 24-hr 2-yr Storm Rainfall=3.00"

Prepared by {enter your company name here}

Page 3

HydroCAD® 7.10 s/n 002940 © 2005 HydroCAD Software Solutions LLC

2/3/2020

Subcatchment 1P: LT SIDE CUL-DE-SAC

Runoff = 0.33 cfs @ 12.01 hrs, Volume= 0.022 af, Depth> 2.59"

Runoff by SCS TR-20 method, UH=SCS, Time Span= 5.00-20.00 hrs, dt= 0.05 hrs
Type III 24-hr 2-yr Storm Rainfall=3.00"

Area (sf)	CN	Description
4,355	98	Paved parking & roofs

Tc (min)	Length (feet)	Slope (ft/ft)	Velocity (ft/sec)	Capacity (cfs)	Description
0.6	75	0.0100	2.0		Shallow Concentrated Flow, paved culdesac Paved Kv= 20.3 fps

Subcatchment 2P: RT SIDE CUL-DE-SAC

Runoff = 0.18 cfs @ 12.00 hrs, Volume= 0.012 af, Depth> 2.59"

Runoff by SCS TR-20 method, UH=SCS, Time Span= 5.00-20.00 hrs, dt= 0.05 hrs
Type III 24-hr 2-yr Storm Rainfall=3.00"

Area (sf)	CN	Description
2,325	98	Paved roads w/curbs & sewers

Tc (min)	Length (feet)	Slope (ft/ft)	Velocity (ft/sec)	Capacity (cfs)	Description
0.4	50	0.0100	2.0		Shallow Concentrated Flow, paved culdesac Paved Kv= 20.3 fps

Subcatchment 3P: BLDG

Runoff = 0.11 cfs @ 12.07 hrs, Volume= 0.008 af, Depth> 2.59"

Runoff by SCS TR-20 method, UH=SCS, Time Span= 5.00-20.00 hrs, dt= 0.05 hrs
Type III 24-hr 2-yr Storm Rainfall=3.00"

Area (sf)	CN	Description
1,600	98	Paved parking & roofs

Tc (min)	Length (feet)	Slope (ft/ft)	Velocity (ft/sec)	Capacity (cfs)	Description
5.0					Direct Entry, ROOF LEADER

18134 - PROP SITE

Type III 24-hr 2-yr Storm Rainfall=3.00"

Prepared by {enter your company name here}

Page 4

HydroCAD® 7.10 s/n 002940 © 2005 HydroCAD Software Solutions LLC

2/3/2020

Subcatchment 4P: GRADED LOT

Runoff = 0.11 cfs @ 12.28 hrs, Volume= 0.017 af, Depth> 0.23"

Runoff by SCS TR-20 method, UH=SCS, Time Span= 5.00-20.00 hrs, dt= 0.05 hrs
Type III 24-hr 2-yr Storm Rainfall=3.00"

Area (sf)	CN	Description
37,259	58	Woods/grass comb., Good, HSG B

Tc (min)	Length (feet)	Slope (ft/ft)	Velocity (ft/sec)	Capacity (cfs)	Description
0.4	60	0.1500	2.7		Shallow Concentrated Flow, landscaped steeper portion Short Grass Pasture Kv= 7.0 fps
4.7	280	0.0200	1.0		Shallow Concentrated Flow, Landscaped areas Short Grass Pasture Kv= 7.0 fps
5.1	340	Total			

Pond CB1: CB-1

Inflow Area = 0.100 ac, Inflow Depth > 2.59" for 2-yr Storm event
 Inflow = 0.33 cfs @ 12.01 hrs, Volume= 0.022 af
 Outflow = 0.33 cfs @ 12.01 hrs, Volume= 0.020 af, Atten= 0%, Lag= 0.1 min
 Primary = 0.33 cfs @ 12.01 hrs, Volume= 0.020 af
 Secondary = 0.00 cfs @ 5.00 hrs, Volume= 0.000 af

Routing by Stor-Ind method, Time Span= 5.00-20.00 hrs, dt= 0.05 hrs
 Peak Elev= 596.44' @ 12.01 hrs Surf.Area= 13 sf Storage= 54 cf
 Flood Elev= 599.25' Surf.Area= 13 sf Storage= 90 cf
 Plug-Flow detention time= 40.1 min calculated for 0.020 af (95% of inflow)
 Center-of-Mass det. time= 18.9 min (754.1 - 735.2)

Volume	Invert	Avail.Storage	Storage Description
#1	592.11'	101 cf	4.00'D x 8.00'H Vertical Cone/Cylinder

Device	Routing	Invert	Outlet Devices
#1	Primary	596.11'	8.0" x 31.0' long Culvert RCP, sq.cut end projecting, Ke= 0.500 Outlet Invert= 595.80' S= 0.0100 '/' Cc= 0.900 n= 0.010 PVC, smooth interior
#2	Secondary	599.25'	2.00' x 2.00' Horiz. Orifice/Grate Limited to weir flow C= 0.600

Primary OutFlow Max=0.32 cfs @ 12.01 hrs HW=596.43' (Free Discharge)
 ↑1=Culvert (Inlet Controls 0.32 cfs @ 1.9 fps)

Secondary OutFlow Max=0.00 cfs @ 5.00 hrs HW=592.13' (Free Discharge)
 ↑2=Orifice/Grate (Controls 0.00 cfs)

18134 - PROP SITE

Type III 24-hr 2-yr Storm Rainfall=3.00"

Prepared by {enter your company name here}

Page 5

HydroCAD® 7.10 s/n 002940 © 2005 HydroCAD Software Solutions LLC

2/3/2020

Pond CB2: CB-2

Inflow Area = 0.053 ac, Inflow Depth > 2.59" for 2-yr Storm event
 Inflow = 0.18 cfs @ 12.00 hrs, Volume= 0.012 af
 Outflow = 0.18 cfs @ 12.01 hrs, Volume= 0.010 af, Atten= 1%, Lag= 0.2 min
 Primary = 0.18 cfs @ 12.01 hrs, Volume= 0.010 af
 Secondary = 0.00 cfs @ 5.00 hrs, Volume= 0.000 af

Routing by Stor-Ind method, Time Span= 5.00-20.00 hrs, dt= 0.05 hrs
 Peak Elev= 596.46' @ 12.01 hrs Surf.Area= 13 sf Storage= 53 cf
 Flood Elev= 599.25' Surf.Area= 13 sf Storage= 88 cf
 Plug-Flow detention time= 64.3 min calculated for 0.010 af (90% of inflow)
 Center-of-Mass det. time= 30.4 min (765.5 - 735.0)

Volume	Invert	Avail.Storage	Storage Description
#1	592.26'	88 cf	4.00'D x 7.00'H Vertical Cone/Cylinder

Device	Routing	Invert	Outlet Devices
#1	Primary	596.25'	8.0" x 45.0' long Culvert RCP, groove end projecting, Ke= 0.200 Outlet Invert= 595.80' S= 0.0100 '/' Cc= 0.900 n= 0.010 PVC, smooth interior
#2	Secondary	599.25'	2.00' x 2.00' Horiz. Orifice/Grate Limited to weir flow C= 0.600

Primary OutFlow Max=0.17 cfs @ 12.01 hrs HW=596.46' (Free Discharge)

↑**1=Culvert** (Barrel Controls 0.17 cfs @ 2.7 fps)

Secondary OutFlow Max=0.00 cfs @ 5.00 hrs HW=592.27' (Free Discharge)

↑**2=Orifice/Grate** (Controls 0.00 cfs)

Pond DMH: DMH

Inflow Area = 0.153 ac, Inflow Depth > 2.41" for 2-yr Storm event
 Inflow = 0.50 cfs @ 12.01 hrs, Volume= 0.031 af
 Outflow = 0.50 cfs @ 12.01 hrs, Volume= 0.031 af, Atten= 0%, Lag= 0.0 min
 Primary = 0.50 cfs @ 12.01 hrs, Volume= 0.031 af
 Secondary = 0.00 cfs @ 5.00 hrs, Volume= 0.000 af

Routing by Stor-Ind method, Time Span= 5.00-20.00 hrs, dt= 0.05 hrs
 Peak Elev= 596.02' @ 12.01 hrs
 Plug-Flow detention time= (not calculated: outflow precedes inflow)
 Center-of-Mass det. time= 0.0 min (757.9 - 757.9)

Device	Routing	Invert	Outlet Devices
#1	Primary	595.65'	15.0" x 58.0' long Culvert RCP, sq.cut end projecting, Ke= 0.500 Outlet Invert= 595.36' S= 0.0050 '/' Cc= 0.900 n= 0.012 Concrete pipe, finished
#2	Secondary	599.90'	2.0" Horiz. Orifice/Grate Limited to weir flow C= 0.600

18134 - PROP SITE

Type III 24-hr 2-yr Storm Rainfall=3.00"

Prepared by {enter your company name here}

Page 6

HydroCAD® 7.10 s/n 002940 © 2005 HydroCAD Software Solutions LLC

2/3/2020

Primary OutFlow Max=0.49 cfs @ 12.01 hrs HW=596.02' (Free Discharge)

↑1=Culvert (Barrel Controls 0.49 cfs @ 2.4 fps)

Secondary OutFlow Max=0.00 cfs @ 5.00 hrs HW=595.65' (Free Discharge)

↑2=Orifice/Grate (Controls 0.00 cfs)

Pond INF1: INF-1

Inflow Area = 0.037 ac, Inflow Depth > 2.59" for 2-yr Storm event
 Inflow = 0.11 cfs @ 12.07 hrs, Volume= 0.008 af
 Outflow = 0.01 cfs @ 13.60 hrs, Volume= 0.005 af, Atten= 94%, Lag= 91.7 min
 Discarded = 0.01 cfs @ 13.60 hrs, Volume= 0.005 af
 Secondary = 0.00 cfs @ 5.00 hrs, Volume= 0.000 af

Routing by Stor-Ind method, Time Span= 5.00-20.00 hrs, dt= 0.05 hrs
 Peak Elev= 597.03' @ 13.60 hrs Surf.Area= 0.005 ac Storage= 0.004 af
 Plug-Flow detention time= 196.8 min calculated for 0.005 af (66% of inflow)
 Center-of-Mass det. time= 123.8 min (862.3 - 738.5)

Volume	Invert	Avail.Storage	Storage Description
#1	594.50'	0.004 af	4.00'W x 20.00'L x 3.00'H Prismatic Z=1.0 0.011 af Overall - 0.001 af Embedded = 0.010 af x 40.0% Voids
#2	595.00'	0.001 af	24.0"D x 20.00'L Horizontal Cylinder S= 0.0050 ' /'Inside #1
		0.005 af	Total Available Storage

Device	Routing	Invert	Outlet Devices
#1	Discarded	594.00'	1.000 in/hr Exfiltration over Wetted area above invert Excluded Wetted area = 0.000 ac
#2	Secondary	601.00'	6.0" Horiz. Orifice/Grate Limited to weir flow C= 0.600

Discarded OutFlow Max=0.01 cfs @ 13.60 hrs HW=597.03' (Free Discharge)

↑1=Exfiltration (Exfiltration Controls 0.01 cfs)

Secondary OutFlow Max=0.00 cfs @ 5.00 hrs HW=594.50' (Free Discharge)

↑2=Orifice/Grate (Controls 0.00 cfs)

Pond SWALE: SWALE

Inflow Area = 0.153 ac, Inflow Depth > 2.41" for 2-yr Storm event
 Inflow = 0.50 cfs @ 12.01 hrs, Volume= 0.031 af
 Outflow = 0.44 cfs @ 12.07 hrs, Volume= 0.024 af, Atten= 13%, Lag= 3.5 min
 Discarded = 0.02 cfs @ 12.07 hrs, Volume= 0.013 af
 Primary = 0.42 cfs @ 12.07 hrs, Volume= 0.010 af

Routing by Stor-Ind method, Time Span= 5.00-20.00 hrs, dt= 0.05 hrs
 Peak Elev= 595.33' @ 12.07 hrs Surf.Area= 0.016 ac Storage= 0.011 af
 Plug-Flow detention time= 121.8 min calculated for 0.024 af (76% of inflow)
 Center-of-Mass det. time= 66.4 min (824.3 - 757.9)

18134 - PROP SITE

Type III 24-hr 2-yr Storm Rainfall=3.00"

Prepared by {enter your company name here}

Page 7

HydroCAD® 7.10 s/n 002940 © 2005 HydroCAD Software Solutions LLC

2/3/2020

Volume	Invert	Avail.Storage	Storage Description
#1	594.40'	0.021 af	4.00'W x 85.00'L x 1.50'H Prismatic Z=2.0

Device	Routing	Invert	Outlet Devices
#1	Discarded	0.00'	1.000 in/hr Exfiltration over Wetted area
#2	Primary	595.25'	5.0' long (Profile 9) Broad-Crested Rectangular Weir Head (feet) 1.97 2.46 2.95 3.94 4.92 Coef. (English) 3.55 3.55 3.57 3.60 3.66

Discarded OutFlow Max=0.02 cfs @ 12.07 hrs HW=595.33' (Free Discharge)↑**1=Exfiltration** (Exfiltration Controls 0.02 cfs)**Primary OutFlow** Max=0.37 cfs @ 12.07 hrs HW=595.33' (Free Discharge)↑**2=Broad-Crested Rectangular Weir** (Weir Controls 0.37 cfs @ 1.0 fps)**Link DP1: DP1**

Inflow Area = 1.045 ac, Inflow Depth > 0.31" for 2-yr Storm event
 Inflow = 0.46 cfs @ 12.07 hrs, Volume= 0.027 af
 Primary = 0.46 cfs @ 12.07 hrs, Volume= 0.027 af, Atten= 0%, Lag= 0.0 min

Primary outflow = Inflow, Time Span= 5.00-20.00 hrs, dt= 0.05 hrs

18134 - PROP SITE

Prepared by {enter your company name here}

HydroCAD® 7.10 s/n 002940 © 2005 HydroCAD Software Solutions LLC

18134-prop

Type III 24-hr 10-yr Storm Rainfall=4.50"

Page 8

2/3/2020

Time span=5.00-20.00 hrs, dt=0.05 hrs, 301 points

Runoff by SCS TR-20 method, UH=SCS

Reach routing by Stor-Ind+Trans method - Pond routing by Stor-Ind method

Subcatchment 1P: LT SIDE CUL-DE-SACRunoff Area=4,355 sf Runoff Depth>3.96"
Flow Length=75' Tc=0.6 min CN=98 Runoff=0.50 cfs 0.033 af**Subcatchment 2P: RT SIDE CUL-DE-SAC**Runoff Area=2,325 sf Runoff Depth>3.96"
Flow Length=50' Tc=0.4 min CN=98 Runoff=0.27 cfs 0.018 af**Subcatchment 3P: BLDG**Runoff Area=1,600 sf Runoff Depth>3.96"
Tc=5.0 min CN=98 Runoff=0.16 cfs 0.012 af**Subcatchment 4P: GRADED LOT**Runoff Area=37,259 sf Runoff Depth>0.81"
Flow Length=340' Tc=5.1 min CN=58 Runoff=0.75 cfs 0.058 af**Pond CB1: CB-1**Peak Elev=596.52' Storage=55 cf Inflow=0.50 cfs 0.033 af
Primary=0.50 cfs 0.032 af Secondary=0.00 cfs 0.000 af Outflow=0.50 cfs 0.032 af**Pond CB2: CB-2**Peak Elev=596.51' Storage=53 cf Inflow=0.27 cfs 0.018 af
Primary=0.27 cfs 0.016 af Secondary=0.00 cfs 0.000 af Outflow=0.27 cfs 0.016 af**Pond DMH: DMH**Peak Elev=596.12' Inflow=0.76 cfs 0.048 af
Primary=0.76 cfs 0.048 af Secondary=0.00 cfs 0.000 af Outflow=0.76 cfs 0.048 af**Pond INF1: INF-1**Peak Elev=601.07' Storage=0.005 af Inflow=0.16 cfs 0.012 af
Discarded=0.01 cfs 0.006 af Secondary=0.09 cfs 0.002 af Outflow=0.10 cfs 0.008 af**Pond SWALE: SWALE**Peak Elev=595.37' Storage=0.011 af Inflow=0.76 cfs 0.048 af
Discarded=0.02 cfs 0.015 af Primary=0.69 cfs 0.025 af Outflow=0.71 cfs 0.040 af**Link DP1: DP1**Inflow=1.33 cfs 0.083 af
Primary=1.33 cfs 0.083 af

18134 - PROP SITE

Type III 24-hr 10-yr Storm Rainfall=4.50"

Prepared by {enter your company name here}

Page 9

HydroCAD® 7.10 s/n 002940 © 2005 HydroCAD Software Solutions LLC

2/3/2020

Subcatchment 1P: LT SIDE CUL-DE-SAC

Runoff = 0.50 cfs @ 12.01 hrs, Volume= 0.033 af, Depth> 3.96"

Runoff by SCS TR-20 method, UH=SCS, Time Span= 5.00-20.00 hrs, dt= 0.05 hrs
Type III 24-hr 10-yr Storm Rainfall=4.50"

Area (sf)	CN	Description
4,355	98	Paved parking & roofs

Tc (min)	Length (feet)	Slope (ft/ft)	Velocity (ft/sec)	Capacity (cfs)	Description
0.6	75	0.0100	2.0		Shallow Concentrated Flow, paved culdesac Paved Kv= 20.3 fps

Subcatchment 2P: RT SIDE CUL-DE-SAC

Runoff = 0.27 cfs @ 12.00 hrs, Volume= 0.018 af, Depth> 3.96"

Runoff by SCS TR-20 method, UH=SCS, Time Span= 5.00-20.00 hrs, dt= 0.05 hrs
Type III 24-hr 10-yr Storm Rainfall=4.50"

Area (sf)	CN	Description
2,325	98	Paved roads w/curbs & sewers

Tc (min)	Length (feet)	Slope (ft/ft)	Velocity (ft/sec)	Capacity (cfs)	Description
0.4	50	0.0100	2.0		Shallow Concentrated Flow, paved culdesac Paved Kv= 20.3 fps

Subcatchment 3P: BLDG

Runoff = 0.16 cfs @ 12.07 hrs, Volume= 0.012 af, Depth> 3.96"

Runoff by SCS TR-20 method, UH=SCS, Time Span= 5.00-20.00 hrs, dt= 0.05 hrs
Type III 24-hr 10-yr Storm Rainfall=4.50"

Area (sf)	CN	Description
1,600	98	Paved parking & roofs

Tc (min)	Length (feet)	Slope (ft/ft)	Velocity (ft/sec)	Capacity (cfs)	Description
5.0					Direct Entry, ROOF LEADER

18134 - PROP SITE

Type III 24-hr 10-yr Storm Rainfall=4.50"

Prepared by {enter your company name here}

Page 10

HydroCAD® 7.10 s/n 002940 © 2005 HydroCAD Software Solutions LLC

2/3/2020

Subcatchment 4P: GRADED LOT

Runoff = 0.75 cfs @ 12.10 hrs, Volume= 0.058 af, Depth> 0.81"

Runoff by SCS TR-20 method, UH=SCS, Time Span= 5.00-20.00 hrs, dt= 0.05 hrs
Type III 24-hr 10-yr Storm Rainfall=4.50"

Area (sf)	CN	Description
37,259	58	Woods/grass comb., Good, HSG B

Tc (min)	Length (feet)	Slope (ft/ft)	Velocity (ft/sec)	Capacity (cfs)	Description
0.4	60	0.1500	2.7		Shallow Concentrated Flow, landscaped steeper portion Short Grass Pasture Kv= 7.0 fps
4.7	280	0.0200	1.0		Shallow Concentrated Flow, Landscaped areas Short Grass Pasture Kv= 7.0 fps
5.1	340	Total			

Pond CB1: CB-1

Inflow Area = 0.100 ac, Inflow Depth > 3.96" for 10-yr Storm event
 Inflow = 0.50 cfs @ 12.01 hrs, Volume= 0.033 af
 Outflow = 0.50 cfs @ 12.01 hrs, Volume= 0.032 af, Atten= 0%, Lag= 0.1 min
 Primary = 0.50 cfs @ 12.01 hrs, Volume= 0.032 af
 Secondary = 0.00 cfs @ 5.00 hrs, Volume= 0.000 af

Routing by Stor-Ind method, Time Span= 5.00-20.00 hrs, dt= 0.05 hrs
 Peak Elev= 596.52' @ 12.01 hrs Surf.Area= 13 sf Storage= 55 cf
 Flood Elev= 599.25' Surf.Area= 13 sf Storage= 90 cf
 Plug-Flow detention time= 28.1 min calculated for 0.032 af (96% of inflow)
 Center-of-Mass det. time= 13.5 min (745.3 - 731.8)

Volume	Invert	Avail.Storage	Storage Description
#1	592.11'	101 cf	4.00'D x 8.00'H Vertical Cone/Cylinder

Device	Routing	Invert	Outlet Devices
#1	Primary	596.11'	8.0" x 31.0' long Culvert RCP, sq.cut end projecting, Ke= 0.500 Outlet Invert= 595.80' S= 0.0100 '/' Cc= 0.900 n= 0.010 PVC, smooth interior
#2	Secondary	599.25'	2.00' x 2.00' Horiz. Orifice/Grate Limited to weir flow C= 0.600

Primary OutFlow Max=0.48 cfs @ 12.01 hrs HW=596.51' (Free Discharge)
 ↑1=Culvert (Inlet Controls 0.48 cfs @ 2.2 fps)

Secondary OutFlow Max=0.00 cfs @ 5.00 hrs HW=592.15' (Free Discharge)
 ↑2=Orifice/Grate (Controls 0.00 cfs)

18134 - PROP SITE

Type III 24-hr 10-yr Storm Rainfall=4.50"

Prepared by {enter your company name here}

Page 11

HydroCAD® 7.10 s/n 002940 © 2005 HydroCAD Software Solutions LLC

2/3/2020

Pond CB2: CB-2

Inflow Area = 0.053 ac, Inflow Depth > 3.96" for 10-yr Storm event
 Inflow = 0.27 cfs @ 12.00 hrs, Volume= 0.018 af
 Outflow = 0.27 cfs @ 12.01 hrs, Volume= 0.016 af, Atten= 0%, Lag= 0.1 min
 Primary = 0.27 cfs @ 12.01 hrs, Volume= 0.016 af
 Secondary = 0.00 cfs @ 5.00 hrs, Volume= 0.000 af

Routing by Stor-Ind method, Time Span= 5.00-20.00 hrs, dt= 0.05 hrs
 Peak Elev= 596.51' @ 12.01 hrs Surf.Area= 13 sf Storage= 53 cf
 Flood Elev= 599.25' Surf.Area= 13 sf Storage= 88 cf
 Plug-Flow detention time= 47.7 min calculated for 0.016 af (93% of inflow)
 Center-of-Mass det. time= 22.6 min (754.2 - 731.6)

Volume	Invert	Avail.Storage	Storage Description
#1	592.26'	88 cf	4.00'D x 7.00'H Vertical Cone/Cylinder

Device	Routing	Invert	Outlet Devices
#1	Primary	596.25'	8.0" x 45.0' long Culvert RCP, groove end projecting, Ke= 0.200 Outlet Invert= 595.80' S= 0.0100 '/' Cc= 0.900 n= 0.010 PVC, smooth interior
#2	Secondary	599.25'	2.00' x 2.00' Horiz. Orifice/Grate Limited to weir flow C= 0.600

Primary OutFlow Max=0.26 cfs @ 12.01 hrs HW=596.51' (Free Discharge)

↑**1=Culvert** (Barrel Controls 0.26 cfs @ 3.0 fps)

Secondary OutFlow Max=0.00 cfs @ 5.00 hrs HW=592.28' (Free Discharge)

↑**2=Orifice/Grate** (Controls 0.00 cfs)

Pond DMH: DMH

Inflow Area = 0.153 ac, Inflow Depth > 3.78" for 10-yr Storm event
 Inflow = 0.76 cfs @ 12.01 hrs, Volume= 0.048 af
 Outflow = 0.76 cfs @ 12.01 hrs, Volume= 0.048 af, Atten= 0%, Lag= 0.0 min
 Primary = 0.76 cfs @ 12.01 hrs, Volume= 0.048 af
 Secondary = 0.00 cfs @ 5.00 hrs, Volume= 0.000 af

Routing by Stor-Ind method, Time Span= 5.00-20.00 hrs, dt= 0.05 hrs
 Peak Elev= 596.12' @ 12.01 hrs
 Plug-Flow detention time= (not calculated: outflow precedes inflow)
 Center-of-Mass det. time= 0.0 min (748.3 - 748.3)

Device	Routing	Invert	Outlet Devices
#1	Primary	595.65'	15.0" x 58.0' long Culvert RCP, sq.cut end projecting, Ke= 0.500 Outlet Invert= 595.36' S= 0.0050 '/' Cc= 0.900 n= 0.012 Concrete pipe, finished
#2	Secondary	599.90'	2.0" Horiz. Orifice/Grate Limited to weir flow C= 0.600

18134 - PROP SITE

Type III 24-hr 10-yr Storm Rainfall=4.50"

Prepared by {enter your company name here}

Page 12

HydroCAD® 7.10 s/n 002940 © 2005 HydroCAD Software Solutions LLC

2/3/2020

Primary OutFlow Max=0.74 cfs @ 12.01 hrs HW=596.11' (Free Discharge)

↑1=Culvert (Barrel Controls 0.74 cfs @ 2.7 fps)

Secondary OutFlow Max=0.00 cfs @ 5.00 hrs HW=595.65' (Free Discharge)

↑2=Orifice/Grate (Controls 0.00 cfs)

Pond INF1: INF-1

Inflow Area = 0.037 ac, Inflow Depth > 3.96" for 10-yr Storm event
 Inflow = 0.16 cfs @ 12.07 hrs, Volume= 0.012 af
 Outflow = 0.10 cfs @ 12.24 hrs, Volume= 0.008 af, Atten= 41%, Lag= 10.5 min
 Discarded = 0.01 cfs @ 12.20 hrs, Volume= 0.006 af
 Secondary = 0.09 cfs @ 12.24 hrs, Volume= 0.002 af

Routing by Stor-Ind method, Time Span= 5.00-20.00 hrs, dt= 0.05 hrs
 Peak Elev= 601.07' @ 12.25 hrs Surf.Area= 0.006 ac Storage= 0.005 af
 Plug-Flow detention time= 166.6 min calculated for 0.008 af (68% of inflow)
 Center-of-Mass det. time= 96.7 min (831.8 - 735.0)

Volume	Invert	Avail.Storage	Storage Description
#1	594.50'	0.004 af	4.00'W x 20.00'L x 3.00'H Prismatic Z=1.0 0.011 af Overall - 0.001 af Embedded = 0.010 af x 40.0% Voids
#2	595.00'	0.001 af	24.0"D x 20.00'L Horizontal Cylinder S= 0.0050 'I'Inside #1
		0.005 af	Total Available Storage

Device	Routing	Invert	Outlet Devices
#1	Discarded	594.00'	1.000 in/hr Exfiltration over Wetted area above invert Excluded Wetted area = 0.000 ac
#2	Secondary	601.00'	6.0" Horiz. Orifice/Grate Limited to weir flow C= 0.600

Discarded OutFlow Max=0.01 cfs @ 12.20 hrs HW=601.04' (Free Discharge)

↑1=Exfiltration (Exfiltration Controls 0.01 cfs)

Secondary OutFlow Max=0.08 cfs @ 12.24 hrs HW=601.06' (Free Discharge)

↑2=Orifice/Grate (Weir Controls 0.08 cfs @ 0.8 fps)

Pond SWALE: SWALE

Inflow Area = 0.153 ac, Inflow Depth > 3.78" for 10-yr Storm event
 Inflow = 0.76 cfs @ 12.01 hrs, Volume= 0.048 af
 Outflow = 0.71 cfs @ 12.04 hrs, Volume= 0.040 af, Atten= 7%, Lag= 1.7 min
 Discarded = 0.02 cfs @ 12.04 hrs, Volume= 0.015 af
 Primary = 0.69 cfs @ 12.04 hrs, Volume= 0.025 af

Routing by Stor-Ind method, Time Span= 5.00-20.00 hrs, dt= 0.05 hrs
 Peak Elev= 595.37' @ 12.04 hrs Surf.Area= 0.016 ac Storage= 0.011 af
 Plug-Flow detention time= 88.7 min calculated for 0.040 af (82% of inflow)
 Center-of-Mass det. time= 40.1 min (788.4 - 748.3)

18134 - PROP SITE

Type III 24-hr 10-yr Storm Rainfall=4.50"

Prepared by {enter your company name here}

Page 13

HydroCAD® 7.10 s/n 002940 © 2005 HydroCAD Software Solutions LLC

2/3/2020

Volume	Invert	Avail.Storage	Storage Description
#1	594.40'	0.021 af	4.00'W x 85.00'L x 1.50'H Prismatic Z=2.0

Device	Routing	Invert	Outlet Devices
#1	Discarded	0.00'	1.000 in/hr Exfiltration over Wetted area
#2	Primary	595.25'	5.0' long (Profile 9) Broad-Crested Rectangular Weir Head (feet) 1.97 2.46 2.95 3.94 4.92 Coef. (English) 3.55 3.55 3.57 3.60 3.66

Discarded OutFlow Max=0.02 cfs @ 12.04 hrs HW=595.36' (Free Discharge)↑**1=Exfiltration** (Exfiltration Controls 0.02 cfs)**Primary OutFlow** Max=0.67 cfs @ 12.04 hrs HW=595.36' (Free Discharge)↑**2=Broad-Crested Rectangular Weir** (Weir Controls 0.67 cfs @ 1.2 fps)**Link DP1: DP1**

Inflow Area = 1.045 ac, Inflow Depth > 0.95" for 10-yr Storm event
 Inflow = 1.33 cfs @ 12.07 hrs, Volume= 0.083 af
 Primary = 1.33 cfs @ 12.07 hrs, Volume= 0.083 af, Atten= 0%, Lag= 0.0 min

Primary outflow = Inflow, Time Span= 5.00-20.00 hrs, dt= 0.05 hrs

18134 - PROP SITE

Prepared by {enter your company name here}

HydroCAD® 7.10 s/n 002940 © 2005 HydroCAD Software Solutions LLC

18134-prop

Type III 24-hr 25-yr Storm Rainfall=5.25"

Page 14

2/3/2020

Time span=5.00-20.00 hrs, dt=0.05 hrs, 301 points

Runoff by SCS TR-20 method, UH=SCS

Reach routing by Stor-Ind+Trans method - Pond routing by Stor-Ind method

Subcatchment 1P: LT SIDE CUL-DE-SACRunoff Area=4,355 sf Runoff Depth>4.65"
Flow Length=75' Tc=0.6 min CN=98 Runoff=0.58 cfs 0.039 af**Subcatchment 2P: RT SIDE CUL-DE-SAC**Runoff Area=2,325 sf Runoff Depth>4.65"
Flow Length=50' Tc=0.4 min CN=98 Runoff=0.31 cfs 0.021 af**Subcatchment 3P: BLDG**Runoff Area=1,600 sf Runoff Depth>4.65"
Tc=5.0 min CN=98 Runoff=0.19 cfs 0.014 af**Subcatchment 4P: GRADED LOT**Runoff Area=37,259 sf Runoff Depth>1.18"
Flow Length=340' Tc=5.1 min CN=58 Runoff=1.17 cfs 0.084 af**Pond CB1: CB-1**Peak Elev=596.56' Storage=56 cf Inflow=0.58 cfs 0.039 af
Primary=0.58 cfs 0.038 af Secondary=0.00 cfs 0.000 af Outflow=0.58 cfs 0.038 af**Pond CB2: CB-2**Peak Elev=596.54' Storage=54 cf Inflow=0.31 cfs 0.021 af
Primary=0.31 cfs 0.020 af Secondary=0.00 cfs 0.000 af Outflow=0.31 cfs 0.020 af**Pond DMH: DMH**Peak Elev=596.16' Inflow=0.89 cfs 0.057 af
Primary=0.89 cfs 0.057 af Secondary=0.00 cfs 0.000 af Outflow=0.89 cfs 0.057 af**Pond INF1: INF-1**Peak Elev=601.12' Storage=0.005 af Inflow=0.19 cfs 0.014 af
Discarded=0.01 cfs 0.007 af Secondary=0.22 cfs 0.004 af Outflow=0.23 cfs 0.010 af**Pond SWALE: SWALE**Peak Elev=595.38' Storage=0.012 af Inflow=0.89 cfs 0.057 af
Discarded=0.02 cfs 0.015 af Primary=0.82 cfs 0.033 af Outflow=0.83 cfs 0.048 af**Link DP1: DP1**Inflow=1.87 cfs 0.117 af
Primary=1.87 cfs 0.117 af

18134 - PROP SITE

Type III 24-hr 25-yr Storm Rainfall=5.25"

Prepared by {enter your company name here}

Page 15

HydroCAD® 7.10 s/n 002940 © 2005 HydroCAD Software Solutions LLC

2/3/2020

Subcatchment 1P: LT SIDE CUL-DE-SAC

Runoff = 0.58 cfs @ 12.01 hrs, Volume= 0.039 af, Depth> 4.65"

Runoff by SCS TR-20 method, UH=SCS, Time Span= 5.00-20.00 hrs, dt= 0.05 hrs
Type III 24-hr 25-yr Storm Rainfall=5.25"

Area (sf)	CN	Description
4,355	98	Paved parking & roofs

Tc (min)	Length (feet)	Slope (ft/ft)	Velocity (ft/sec)	Capacity (cfs)	Description
0.6	75	0.0100	2.0		Shallow Concentrated Flow, paved culdesac Paved Kv= 20.3 fps

Subcatchment 2P: RT SIDE CUL-DE-SAC

Runoff = 0.31 cfs @ 12.00 hrs, Volume= 0.021 af, Depth> 4.65"

Runoff by SCS TR-20 method, UH=SCS, Time Span= 5.00-20.00 hrs, dt= 0.05 hrs
Type III 24-hr 25-yr Storm Rainfall=5.25"

Area (sf)	CN	Description
2,325	98	Paved roads w/curbs & sewers

Tc (min)	Length (feet)	Slope (ft/ft)	Velocity (ft/sec)	Capacity (cfs)	Description
0.4	50	0.0100	2.0		Shallow Concentrated Flow, paved culdesac Paved Kv= 20.3 fps

Subcatchment 3P: BLDG

Runoff = 0.19 cfs @ 12.07 hrs, Volume= 0.014 af, Depth> 4.65"

Runoff by SCS TR-20 method, UH=SCS, Time Span= 5.00-20.00 hrs, dt= 0.05 hrs
Type III 24-hr 25-yr Storm Rainfall=5.25"

Area (sf)	CN	Description
1,600	98	Paved parking & roofs

Tc (min)	Length (feet)	Slope (ft/ft)	Velocity (ft/sec)	Capacity (cfs)	Description
5.0					Direct Entry, ROOF LEADER

18134 - PROP SITE

Type III 24-hr 25-yr Storm Rainfall=5.25"

Prepared by {enter your company name here}

Page 16

HydroCAD® 7.10 s/n 002940 © 2005 HydroCAD Software Solutions LLC

2/3/2020

Subcatchment 4P: GRADED LOT

Runoff = 1.17 cfs @ 12.09 hrs, Volume= 0.084 af, Depth> 1.18"

Runoff by SCS TR-20 method, UH=SCS, Time Span= 5.00-20.00 hrs, dt= 0.05 hrs
Type III 24-hr 25-yr Storm Rainfall=5.25"

Area (sf)	CN	Description
37,259	58	Woods/grass comb., Good, HSG B

Tc (min)	Length (feet)	Slope (ft/ft)	Velocity (ft/sec)	Capacity (cfs)	Description
0.4	60	0.1500	2.7		Shallow Concentrated Flow, landscaped steeper portion Short Grass Pasture Kv= 7.0 fps
4.7	280	0.0200	1.0		Shallow Concentrated Flow, Landscaped areas Short Grass Pasture Kv= 7.0 fps
5.1	340	Total			

Pond CB1: CB-1

Inflow Area = 0.100 ac, Inflow Depth > 4.65" for 25-yr Storm event
 Inflow = 0.58 cfs @ 12.01 hrs, Volume= 0.039 af
 Outflow = 0.58 cfs @ 12.01 hrs, Volume= 0.038 af, Atten= 0%, Lag= 0.1 min
 Primary = 0.58 cfs @ 12.01 hrs, Volume= 0.038 af
 Secondary = 0.00 cfs @ 5.00 hrs, Volume= 0.000 af

Routing by Stor-Ind method, Time Span= 5.00-20.00 hrs, dt= 0.05 hrs
 Peak Elev= 596.56' @ 12.01 hrs Surf.Area= 13 sf Storage= 56 cf
 Flood Elev= 599.25' Surf.Area= 13 sf Storage= 90 cf
 Plug-Flow detention time= 24.8 min calculated for 0.038 af (97% of inflow)
 Center-of-Mass det. time= 11.8 min (742.7 - 730.9)

Volume	Invert	Avail.Storage	Storage Description
#1	592.11'	101 cf	4.00'D x 8.00'H Vertical Cone/Cylinder

Device	Routing	Invert	Outlet Devices
#1	Primary	596.11'	8.0" x 31.0' long Culvert RCP, sq.cut end projecting, Ke= 0.500 Outlet Invert= 595.80' S= 0.0100 '/' Cc= 0.900 n= 0.010 PVC, smooth interior
#2	Secondary	599.25'	2.00' x 2.00' Horiz. Orifice/Grate Limited to weir flow C= 0.600

Primary OutFlow Max=0.56 cfs @ 12.01 hrs HW=596.55' (Free Discharge)
 ↑1=Culvert (Inlet Controls 0.56 cfs @ 2.3 fps)

Secondary OutFlow Max=0.00 cfs @ 5.00 hrs HW=592.15' (Free Discharge)
 ↑2=Orifice/Grate (Controls 0.00 cfs)

18134 - PROP SITE

Type III 24-hr 25-yr Storm Rainfall=5.25"

Prepared by {enter your company name here}

Page 17

HydroCAD® 7.10 s/n 002940 © 2005 HydroCAD Software Solutions LLC

2/3/2020

Pond CB2: CB-2

Inflow Area = 0.053 ac, Inflow Depth > 4.65" for 25-yr Storm event
 Inflow = 0.31 cfs @ 12.00 hrs, Volume= 0.021 af
 Outflow = 0.31 cfs @ 12.01 hrs, Volume= 0.020 af, Atten= 0%, Lag= 0.1 min
 Primary = 0.31 cfs @ 12.01 hrs, Volume= 0.020 af
 Secondary = 0.00 cfs @ 5.00 hrs, Volume= 0.000 af

Routing by Stor-Ind method, Time Span= 5.00-20.00 hrs, dt= 0.05 hrs
 Peak Elev= 596.54' @ 12.01 hrs Surf.Area= 13 sf Storage= 54 cf
 Flood Elev= 599.25' Surf.Area= 13 sf Storage= 88 cf
 Plug-Flow detention time= 41.6 min calculated for 0.019 af (94% of inflow)
 Center-of-Mass det. time= 20.0 min (750.7 - 730.7)

Volume	Invert	Avail.Storage	Storage Description
#1	592.26'	88 cf	4.00'D x 7.00'H Vertical Cone/Cylinder

Device	Routing	Invert	Outlet Devices
#1	Primary	596.25'	8.0" x 45.0' long Culvert RCP, groove end projecting, Ke= 0.200 Outlet Invert= 595.80' S= 0.0100 '/' Cc= 0.900 n= 0.010 PVC, smooth interior
#2	Secondary	599.25'	2.00' x 2.00' Horiz. Orifice/Grate Limited to weir flow C= 0.600

Primary OutFlow Max=0.30 cfs @ 12.01 hrs HW=596.53' (Free Discharge)

↑**1=Culvert** (Barrel Controls 0.30 cfs @ 3.1 fps)

Secondary OutFlow Max=0.00 cfs @ 5.00 hrs HW=592.28' (Free Discharge)

↑**2=Orifice/Grate** (Controls 0.00 cfs)

Pond DMH: DMH

Inflow Area = 0.153 ac, Inflow Depth > 4.47" for 25-yr Storm event
 Inflow = 0.89 cfs @ 12.01 hrs, Volume= 0.057 af
 Outflow = 0.89 cfs @ 12.01 hrs, Volume= 0.057 af, Atten= 0%, Lag= 0.0 min
 Primary = 0.89 cfs @ 12.01 hrs, Volume= 0.057 af
 Secondary = 0.00 cfs @ 5.00 hrs, Volume= 0.000 af

Routing by Stor-Ind method, Time Span= 5.00-20.00 hrs, dt= 0.05 hrs
 Peak Elev= 596.16' @ 12.01 hrs
 Plug-Flow detention time= (not calculated: outflow precedes inflow)
 Center-of-Mass det. time= (not calculated: outflow precedes inflow)

Device	Routing	Invert	Outlet Devices
#1	Primary	595.65'	15.0" x 58.0' long Culvert RCP, sq.cut end projecting, Ke= 0.500 Outlet Invert= 595.36' S= 0.0050 '/' Cc= 0.900 n= 0.012 Concrete pipe, finished
#2	Secondary	599.90'	2.0" Horiz. Orifice/Grate Limited to weir flow C= 0.600

18134 - PROP SITE

Type III 24-hr 25-yr Storm Rainfall=5.25"

Prepared by {enter your company name here}

Page 18

HydroCAD® 7.10 s/n 002940 © 2005 HydroCAD Software Solutions LLC

2/3/2020

Primary OutFlow Max=0.86 cfs @ 12.01 hrs HW=596.15' (Free Discharge)

↑1=Culvert (Barrel Controls 0.86 cfs @ 2.8 fps)

Secondary OutFlow Max=0.00 cfs @ 5.00 hrs HW=595.65' (Free Discharge)

↑2=Orifice/Grate (Controls 0.00 cfs)

Pond INF1: INF-1

Inflow Area = 0.037 ac, Inflow Depth > 4.65" for 25-yr Storm event
 Inflow = 0.19 cfs @ 12.07 hrs, Volume= 0.014 af
 Outflow = 0.23 cfs @ 12.14 hrs, Volume= 0.010 af, Atten= 0%, Lag= 4.5 min
 Discarded = 0.01 cfs @ 12.10 hrs, Volume= 0.007 af
 Secondary = 0.22 cfs @ 12.14 hrs, Volume= 0.004 af

Routing by Stor-Ind method, Time Span= 5.00-20.00 hrs, dt= 0.05 hrs
 Peak Elev= 601.12' @ 12.15 hrs Surf.Area= 0.006 ac Storage= 0.005 af
 Plug-Flow detention time= 147.2 min calculated for 0.010 af (71% of inflow)
 Center-of-Mass det. time= 81.0 min (815.1 - 734.1)

Volume	Invert	Avail.Storage	Storage Description
#1	594.50'	0.004 af	4.00'W x 20.00'L x 3.00'H Prismatic Z=1.0 0.011 af Overall - 0.001 af Embedded = 0.010 af x 40.0% Voids
#2	595.00'	0.001 af	24.0"D x 20.00'L Horizontal Cylinder S= 0.0050 'I'Inside #1
		0.005 af	Total Available Storage

Device	Routing	Invert	Outlet Devices
#1	Discarded	594.00'	1.000 in/hr Exfiltration over Wetted area above invert Excluded Wetted area = 0.000 ac
#2	Secondary	601.00'	6.0" Horiz. Orifice/Grate Limited to weir flow C= 0.600

Discarded OutFlow Max=0.01 cfs @ 12.10 hrs HW=601.06' (Free Discharge)

↑1=Exfiltration (Exfiltration Controls 0.01 cfs)

Secondary OutFlow Max=0.20 cfs @ 12.14 hrs HW=601.11' (Free Discharge)

↑2=Orifice/Grate (Weir Controls 0.20 cfs @ 1.1 fps)

Pond SWALE: SWALE

Inflow Area = 0.153 ac, Inflow Depth > 4.47" for 25-yr Storm event
 Inflow = 0.89 cfs @ 12.01 hrs, Volume= 0.057 af
 Outflow = 0.83 cfs @ 12.03 hrs, Volume= 0.048 af, Atten= 7%, Lag= 1.6 min
 Discarded = 0.02 cfs @ 12.03 hrs, Volume= 0.015 af
 Primary = 0.82 cfs @ 12.03 hrs, Volume= 0.033 af

Routing by Stor-Ind method, Time Span= 5.00-20.00 hrs, dt= 0.05 hrs
 Peak Elev= 595.38' @ 12.03 hrs Surf.Area= 0.016 ac Storage= 0.012 af
 Plug-Flow detention time= 80.1 min calculated for 0.048 af (84% of inflow)
 Center-of-Mass det. time= 34.7 min (780.1 - 745.4)

18134 - PROP SITE

Type III 24-hr 25-yr Storm Rainfall=5.25"

Prepared by {enter your company name here}

Page 19

HydroCAD® 7.10 s/n 002940 © 2005 HydroCAD Software Solutions LLC

2/3/2020

Volume	Invert	Avail.Storage	Storage Description
#1	594.40'	0.021 af	4.00'W x 85.00'L x 1.50'H Prismatic Z=2.0

Device	Routing	Invert	Outlet Devices
#1	Discarded	0.00'	1.000 in/hr Exfiltration over Wetted area
#2	Primary	595.25'	5.0' long (Profile 9) Broad-Crested Rectangular Weir Head (feet) 1.97 2.46 2.95 3.94 4.92 Coef. (English) 3.55 3.55 3.57 3.60 3.66

Discarded OutFlow Max=0.02 cfs @ 12.03 hrs HW=595.37' (Free Discharge)↑**1=Exfiltration** (Exfiltration Controls 0.02 cfs)**Primary OutFlow** Max=0.78 cfs @ 12.03 hrs HW=595.37' (Free Discharge)↑**2=Broad-Crested Rectangular Weir** (Weir Controls 0.78 cfs @ 1.3 fps)**Link DP1: DP1**

Inflow Area = 1.045 ac, Inflow Depth > 1.34" for 25-yr Storm event
 Inflow = 1.87 cfs @ 12.07 hrs, Volume= 0.117 af
 Primary = 1.87 cfs @ 12.07 hrs, Volume= 0.117 af, Atten= 0%, Lag= 0.0 min

Primary outflow = Inflow, Time Span= 5.00-20.00 hrs, dt= 0.05 hrs

18134 - PROP SITE

Type III 24-hr 100-yr Storm Rainfall=6.60"

Prepared by {enter your company name here}

Page 20

HydroCAD® 7.10 s/n 002940 © 2005 HydroCAD Software Solutions LLC

2/3/2020

Time span=5.00-20.00 hrs, dt=0.05 hrs, 301 points

Runoff by SCS TR-20 method, UH=SCS

Reach routing by Stor-Ind+Trans method - Pond routing by Stor-Ind method

Subcatchment 1P: LT SIDE CUL-DE-SACRunoff Area=4,355 sf Runoff Depth>5.87"
Flow Length=75' Tc=0.6 min CN=98 Runoff=0.73 cfs 0.049 af**Subcatchment 2P: RT SIDE CUL-DE-SAC**Runoff Area=2,325 sf Runoff Depth>5.87"
Flow Length=50' Tc=0.4 min CN=98 Runoff=0.39 cfs 0.026 af**Subcatchment 3P: BLDG**Runoff Area=1,600 sf Runoff Depth>5.87"
Tc=5.0 min CN=98 Runoff=0.24 cfs 0.018 af**Subcatchment 4P: GRADED LOT**Runoff Area=37,259 sf Runoff Depth>1.95"
Flow Length=340' Tc=5.1 min CN=58 Runoff=2.05 cfs 0.139 af**Pond CB1: CB-1**Peak Elev=596.64' Storage=57 cf Inflow=0.73 cfs 0.049 af
Primary=0.73 cfs 0.048 af Secondary=0.00 cfs 0.000 af Outflow=0.73 cfs 0.048 af**Pond CB2: CB-2**Peak Elev=596.58' Storage=54 cf Inflow=0.39 cfs 0.026 af
Primary=0.39 cfs 0.025 af Secondary=0.00 cfs 0.000 af Outflow=0.39 cfs 0.025 af**Pond DMH: DMH**Peak Elev=596.23' Inflow=1.12 cfs 0.073 af
Primary=1.12 cfs 0.073 af Secondary=0.00 cfs 0.000 af Outflow=1.12 cfs 0.073 af**Pond INF1: INF-1**Peak Elev=601.15' Storage=0.005 af Inflow=0.24 cfs 0.018 af
Discarded=0.01 cfs 0.007 af Secondary=0.30 cfs 0.007 af Outflow=0.31 cfs 0.014 af**Pond SWALE: SWALE**Peak Elev=595.40' Storage=0.012 af Inflow=1.12 cfs 0.073 af
Discarded=0.02 cfs 0.016 af Primary=1.04 cfs 0.047 af Outflow=1.05 cfs 0.063 af**Link DP1: DP1**Inflow=2.94 cfs 0.187 af
Primary=2.94 cfs 0.187 af

18134 - PROP SITE

Type III 24-hr 100-yr Storm Rainfall=6.60"

Prepared by {enter your company name here}

Page 21

HydroCAD® 7.10 s/n 002940 © 2005 HydroCAD Software Solutions LLC

2/3/2020

Subcatchment 1P: LT SIDE CUL-DE-SAC

Runoff = 0.73 cfs @ 12.01 hrs, Volume= 0.049 af, Depth> 5.87"

Runoff by SCS TR-20 method, UH=SCS, Time Span= 5.00-20.00 hrs, dt= 0.05 hrs
Type III 24-hr 100-yr Storm Rainfall=6.60"

Area (sf)	CN	Description
4,355	98	Paved parking & roofs

Tc (min)	Length (feet)	Slope (ft/ft)	Velocity (ft/sec)	Capacity (cfs)	Description
0.6	75	0.0100	2.0		Shallow Concentrated Flow, paved culdesac Paved Kv= 20.3 fps

Subcatchment 2P: RT SIDE CUL-DE-SAC

Runoff = 0.39 cfs @ 12.00 hrs, Volume= 0.026 af, Depth> 5.87"

Runoff by SCS TR-20 method, UH=SCS, Time Span= 5.00-20.00 hrs, dt= 0.05 hrs
Type III 24-hr 100-yr Storm Rainfall=6.60"

Area (sf)	CN	Description
2,325	98	Paved roads w/curbs & sewers

Tc (min)	Length (feet)	Slope (ft/ft)	Velocity (ft/sec)	Capacity (cfs)	Description
0.4	50	0.0100	2.0		Shallow Concentrated Flow, paved culdesac Paved Kv= 20.3 fps

Subcatchment 3P: BLDG

Runoff = 0.24 cfs @ 12.07 hrs, Volume= 0.018 af, Depth> 5.87"

Runoff by SCS TR-20 method, UH=SCS, Time Span= 5.00-20.00 hrs, dt= 0.05 hrs
Type III 24-hr 100-yr Storm Rainfall=6.60"

Area (sf)	CN	Description
1,600	98	Paved parking & roofs

Tc (min)	Length (feet)	Slope (ft/ft)	Velocity (ft/sec)	Capacity (cfs)	Description
5.0					Direct Entry, ROOF LEADER

18134 - PROP SITE

Type III 24-hr 100-yr Storm Rainfall=6.60"

Prepared by {enter your company name here}

Page 22

HydroCAD® 7.10 s/n 002940 © 2005 HydroCAD Software Solutions LLC

2/3/2020

Subcatchment 4P: GRADED LOT

Runoff = 2.05 cfs @ 12.09 hrs, Volume= 0.139 af, Depth> 1.95"

Runoff by SCS TR-20 method, UH=SCS, Time Span= 5.00-20.00 hrs, dt= 0.05 hrs
Type III 24-hr 100-yr Storm Rainfall=6.60"

Area (sf)	CN	Description
37,259	58	Woods/grass comb., Good, HSG B

Tc (min)	Length (feet)	Slope (ft/ft)	Velocity (ft/sec)	Capacity (cfs)	Description
0.4	60	0.1500	2.7		Shallow Concentrated Flow, landscaped steeper portion Short Grass Pasture Kv= 7.0 fps
4.7	280	0.0200	1.0		Shallow Concentrated Flow, Landscaped areas Short Grass Pasture Kv= 7.0 fps
5.1	340	Total			

Pond CB1: CB-1

Inflow Area = 0.100 ac, Inflow Depth > 5.87" for 100-yr Storm event
 Inflow = 0.73 cfs @ 12.01 hrs, Volume= 0.049 af
 Outflow = 0.73 cfs @ 12.01 hrs, Volume= 0.048 af, Atten= 0%, Lag= 0.1 min
 Primary = 0.73 cfs @ 12.01 hrs, Volume= 0.048 af
 Secondary = 0.00 cfs @ 5.00 hrs, Volume= 0.000 af

Routing by Stor-Ind method, Time Span= 5.00-20.00 hrs, dt= 0.05 hrs
 Peak Elev= 596.64' @ 12.01 hrs Surf.Area= 13 sf Storage= 57 cf
 Flood Elev= 599.25' Surf.Area= 13 sf Storage= 90 cf
 Plug-Flow detention time= 20.0 min calculated for 0.048 af (97% of inflow)
 Center-of-Mass det. time= 9.6 min (739.4 - 729.8)

Volume	Invert	Avail.Storage	Storage Description
#1	592.11'	101 cf	4.00'D x 8.00'H Vertical Cone/Cylinder

Device	Routing	Invert	Outlet Devices
#1	Primary	596.11'	8.0" x 31.0' long Culvert RCP, sq.cut end projecting, Ke= 0.500 Outlet Invert= 595.80' S= 0.0100 '/' Cc= 0.900 n= 0.010 PVC, smooth interior
#2	Secondary	599.25'	2.00' x 2.00' Horiz. Orifice/Grate Limited to weir flow C= 0.600

Primary OutFlow Max=0.71 cfs @ 12.01 hrs HW=596.63' (Free Discharge)
 ↑1=Culvert (Inlet Controls 0.71 cfs @ 2.4 fps)

Secondary OutFlow Max=0.00 cfs @ 5.00 hrs HW=592.17' (Free Discharge)
 ↑2=Orifice/Grate (Controls 0.00 cfs)

18134 - PROP SITE

Type III 24-hr 100-yr Storm Rainfall=6.60"

Prepared by {enter your company name here}

Page 23

HydroCAD® 7.10 s/n 002940 © 2005 HydroCAD Software Solutions LLC

2/3/2020

Pond CB2: CB-2

Inflow Area = 0.053 ac, Inflow Depth > 5.87" for 100-yr Storm event
 Inflow = 0.39 cfs @ 12.00 hrs, Volume= 0.026 af
 Outflow = 0.39 cfs @ 12.01 hrs, Volume= 0.025 af, Atten= 0%, Lag= 0.1 min
 Primary = 0.39 cfs @ 12.01 hrs, Volume= 0.025 af
 Secondary = 0.00 cfs @ 5.00 hrs, Volume= 0.000 af

Routing by Stor-Ind method, Time Span= 5.00-20.00 hrs, dt= 0.05 hrs
 Peak Elev= 596.58' @ 12.01 hrs Surf.Area= 13 sf Storage= 54 cf
 Flood Elev= 599.25' Surf.Area= 13 sf Storage= 88 cf
 Plug-Flow detention time= 34.8 min calculated for 0.025 af (96% of inflow)
 Center-of-Mass det. time= 16.6 min (746.2 - 729.7)

Volume	Invert	Avail.Storage	Storage Description
#1	592.26'	88 cf	4.00'D x 7.00'H Vertical Cone/Cylinder

Device	Routing	Invert	Outlet Devices
#1	Primary	596.25'	8.0" x 45.0' long Culvert RCP, groove end projecting, Ke= 0.200 Outlet Invert= 595.80' S= 0.0100 '/' Cc= 0.900 n= 0.010 PVC, smooth interior
#2	Secondary	599.25'	2.00' x 2.00' Horiz. Orifice/Grate Limited to weir flow C= 0.600

Primary OutFlow Max=0.38 cfs @ 12.01 hrs HW=596.57' (Free Discharge)

↑**1=Culvert** (Barrel Controls 0.38 cfs @ 3.3 fps)

Secondary OutFlow Max=0.00 cfs @ 5.00 hrs HW=592.29' (Free Discharge)

↑**2=Orifice/Grate** (Controls 0.00 cfs)

Pond DMH: DMH

Inflow Area = 0.153 ac, Inflow Depth > 5.69" for 100-yr Storm event
 Inflow = 1.12 cfs @ 12.01 hrs, Volume= 0.073 af
 Outflow = 1.12 cfs @ 12.01 hrs, Volume= 0.073 af, Atten= 0%, Lag= 0.0 min
 Primary = 1.12 cfs @ 12.01 hrs, Volume= 0.073 af
 Secondary = 0.00 cfs @ 5.00 hrs, Volume= 0.000 af

Routing by Stor-Ind method, Time Span= 5.00-20.00 hrs, dt= 0.05 hrs
 Peak Elev= 596.23' @ 12.01 hrs
 Plug-Flow detention time= (not calculated: outflow precedes inflow)
 Center-of-Mass det. time= 0.0 min (741.8 - 741.8)

Device	Routing	Invert	Outlet Devices
#1	Primary	595.65'	15.0" x 58.0' long Culvert RCP, sq.cut end projecting, Ke= 0.500 Outlet Invert= 595.36' S= 0.0050 '/' Cc= 0.900 n= 0.012 Concrete pipe, finished
#2	Secondary	599.90'	2.0" Horiz. Orifice/Grate Limited to weir flow C= 0.600

18134 - PROP SITE

Type III 24-hr 100-yr Storm Rainfall=6.60"

Prepared by {enter your company name here}

Page 24

HydroCAD® 7.10 s/n 002940 © 2005 HydroCAD Software Solutions LLC

2/3/2020

Primary OutFlow Max=1.09 cfs @ 12.01 hrs HW=596.22' (Free Discharge)

↑1=Culvert (Barrel Controls 1.09 cfs @ 3.0 fps)

Secondary OutFlow Max=0.00 cfs @ 5.00 hrs HW=595.65' (Free Discharge)

↑2=Orifice/Grate (Controls 0.00 cfs)

Pond INF1: INF-1

Inflow Area = 0.037 ac, Inflow Depth > 5.87" for 100-yr Storm event
 Inflow = 0.24 cfs @ 12.07 hrs, Volume= 0.018 af
 Outflow = 0.31 cfs @ 12.05 hrs, Volume= 0.014 af, Atten= 0%, Lag= 0.0 min
 Discarded = 0.01 cfs @ 12.00 hrs, Volume= 0.007 af
 Secondary = 0.30 cfs @ 12.05 hrs, Volume= 0.007 af

Routing by Stor-Ind method, Time Span= 5.00-20.00 hrs, dt= 0.05 hrs
 Peak Elev= 601.15' @ 12.05 hrs Surf.Area= 0.006 ac Storage= 0.005 af
 Plug-Flow detention time= 125.5 min calculated for 0.014 af (76% of inflow)
 Center-of-Mass det. time= 63.8 min (796.8 - 733.0)

Volume	Invert	Avail.Storage	Storage Description
#1	594.50'	0.004 af	4.00'W x 20.00'L x 3.00'H Prismatic Z=1.0 0.011 af Overall - 0.001 af Embedded = 0.010 af x 40.0% Voids
#2	595.00'	0.001 af	24.0"D x 20.00'L Horizontal Cylinder S= 0.0050 'I'Inside #1
		0.005 af	Total Available Storage

Device	Routing	Invert	Outlet Devices
#1	Discarded	594.00'	1.000 in/hr Exfiltration over Wetted area above invert Excluded Wetted area = 0.000 ac
#2	Secondary	601.00'	6.0" Horiz. Orifice/Grate Limited to weir flow C= 0.600

Discarded OutFlow Max=0.01 cfs @ 12.00 hrs HW=601.06' (Free Discharge)

↑1=Exfiltration (Exfiltration Controls 0.01 cfs)

Secondary OutFlow Max=0.29 cfs @ 12.05 hrs HW=601.15' (Free Discharge)

↑2=Orifice/Grate (Weir Controls 0.29 cfs @ 1.3 fps)

Pond SWALE: SWALE

Inflow Area = 0.153 ac, Inflow Depth > 5.69" for 100-yr Storm event
 Inflow = 1.12 cfs @ 12.01 hrs, Volume= 0.073 af
 Outflow = 1.05 cfs @ 12.03 hrs, Volume= 0.063 af, Atten= 6%, Lag= 1.5 min
 Discarded = 0.02 cfs @ 12.03 hrs, Volume= 0.016 af
 Primary = 1.04 cfs @ 12.03 hrs, Volume= 0.047 af

Routing by Stor-Ind method, Time Span= 5.00-20.00 hrs, dt= 0.05 hrs
 Peak Elev= 595.40' @ 12.03 hrs Surf.Area= 0.016 ac Storage= 0.012 af
 Plug-Flow detention time= 68.8 min calculated for 0.063 af (87% of inflow)
 Center-of-Mass det. time= 29.0 min (770.8 - 741.8)

18134 - PROP SITE

Type III 24-hr 100-yr Storm Rainfall=6.60"

Prepared by {enter your company name here}

Page 25

HydroCAD® 7.10 s/n 002940 © 2005 HydroCAD Software Solutions LLC

2/3/2020

Volume	Invert	Avail.Storage	Storage Description
#1	594.40'	0.021 af	4.00'W x 85.00'L x 1.50'H Prismatic Z=2.0

Device	Routing	Invert	Outlet Devices
#1	Discarded	0.00'	1.000 in/hr Exfiltration over Wetted area
#2	Primary	595.25'	5.0' long (Profile 9) Broad-Crested Rectangular Weir Head (feet) 1.97 2.46 2.95 3.94 4.92 Coef. (English) 3.55 3.55 3.57 3.60 3.66

Discarded OutFlow Max=0.02 cfs @ 12.03 hrs HW=595.40' (Free Discharge)↑**1=Exfiltration** (Exfiltration Controls 0.02 cfs)**Primary OutFlow** Max=0.99 cfs @ 12.03 hrs HW=595.40' (Free Discharge)↑**2=Broad-Crested Rectangular Weir** (Weir Controls 0.99 cfs @ 1.4 fps)**Link DP1: DP1**

Inflow Area = 1.045 ac, Inflow Depth > 2.14" for 100-yr Storm event
 Inflow = 2.94 cfs @ 12.07 hrs, Volume= 0.187 af
 Primary = 2.94 cfs @ 12.07 hrs, Volume= 0.187 af, Atten= 0%, Lag= 0.0 min

Primary outflow = Inflow, Time Span= 5.00-20.00 hrs, dt= 0.05 hrs

8.0 PIPE DESIGN CALCULATIONS

DESIGN of STORM SEWERS RAINFALL & RUNOFF STUDY

Joseph Graham, PE
119 Pike Street
TEWKSBURY, MASSACHUSETTS 01876

Job name: 0 Meadowbrook, Worcester, MA 01609

Job Number: 18134

From	To	Area (S.F.)	Pipe Length (Ft.)	Design Storm (Yr.)	Intensity (i)	Q (c.f.s.)	Size (in.)	Slope (%)	n	Full capacity (c.f.s.)	Full Velocity (f.p.s.)	Rim	inv
CB1	DMH	4,355	31.00	25	6.21	0.72	8	1.0%	0.01	1.58	4.51	599.25	596.25
CB2	DMH	2,329	45.00	25	6.21	0.39	8	1.0%	0.01	1.58	4.51	599.25	596.25
DMH	FES		58.00	25	6.21	1.11	15	0.5%	0.012	4.96	4.04	599.90	595.65

9.0 EROSION AND SEDIMENTATION CONTROL PLAN

This section specifies requirements and suggestions for the erosion & sedimentation control plan for the proposed construction, paving and drainage improvements for 210 Southwest Cutoff.

The Stormwater pollution prevention measures contained herein shall be at least the minimum required by local Regulations. The Contractor shall provide additional measures to prevent pollution from stormwater discharges in compliance with the National Pollution Discharge Elimination System (NPDES) Phase II permit requirements and all other local, state and federal requirements.

The cost of any fines, construction delays and remedial actions resulting from the Contractor's failure to comply with all provisions of local regulations shall be paid for by the Contractor at no additional cost to the Owner.

9.0 CONSTRUCTION GENERAL PERMIT (CGP) INFORMATION

The Contractor shall be solely responsible for erosion and sedimentation control at the site. The Contractor shall utilize a system of operations and all necessary erosion and sedimentation control measures, even if not specified herein or elsewhere, to minimize erosion damage at the site and to prevent the mitigation of sediment into environmentally sensitive areas. Environmentally sensitive areas include all wetland resource areas within, and downstream of, the site and those areas of the site that are not being altered.

The EPA Construction General Permit authorizes stormwater discharges from large and small construction activities that result in a total land disturbance equal to or greater than one (1) acre, where those discharges enter surface water of the united states or a municipal separate storm sewer system leading to surface waters of the United States subject to the conditions set forth in the General Construction Permit (CGP).

To obtain coverage under the General Permit, the operator must prepare and submit a complete and accurate notice of intent to the Environmental Protection Agency (EPA). Discharges are not authorized if the NOI is incomplete or inaccurate or if the site was never eligible for permit coverage.

A Stormwater pollution Prevention Plan (SWPPP) must be prepared prior to submission of a Notice of Intent (NOI). The following plan is intended to serve as the SWPPP for this project.

The EPA has defined the site operator as the party that has day to day operational control of those activities at a project which are necessary to ensure compliance with the stormwater pollution prevention plan for the site or other permit conditions.

It is the responsibility of the applicant/owner to file a notice of intent with the EPA. Discharge of stormwater from construction activities is authorized seven calendar days after acknowledgement of receipt of the completed notice of intent that is posted on the EPA's website: <http://www.epa.gov/npdes/stormwater/cgp>. A copy of the NOI can be obtained from the EPA website.

9.1 SITE AND ACTIVITY DESCRIPTION

The site owner: Buckingham Development LLC

Party Responsible for Maintenance During Construction: Contractor

Party Responsible for Maintenance After Construction Owner

The site area is defined by property boundaries shown on Attachment A, Site Plan, sheets C-1.0 is approximately 47,500 SF (1.1 acres). Approximately 50% of the site will be disturbed for construction, earthwork and grading activities associated with the site development, building, utility, parking and stormwater management construction. The project consists of constructing the proposed excavation, utilities, buildings, driveways, stormwater management structures, and other miscellaneous construction activities indicated on the plans.

The following construction sequence shall be followed:

- a) Installation of erosion controls at all locations
- b) Excavation and site development construction
 - a. Construction of stormwater management structures shall begin as soon as feasible.
 - b. Once the proposed drainage infrastructure and pavement has been installed and accepted for each construction phase, it will be allowed to collect surface runoff and be transported into the constructed basin.
 - c. Provide temporary stabilization measures as construction permits.

Refer to Definitive Subdivision Site plan (Attachment A) dated 2/3/2020 for locations of major structural and non-structural BMP's, where slope stabilization is expected to occur, wetlands and other resource areas, and stormwater discharges. The contractor shall stabilize all disturbed areas with loam and seed unless the area is subject to stabilization by other means (paving, geotextile fabric, etc.). Areas and locations where final stabilization has occurred will be noted and updated on plans by the contractor.

9.2 EROSION AND SEDIMENT CONTROLS

Stormwater controls will include perimeter controls to contain stormwater runoff and prevent erosion and sedimentation of adjacent land areas.

9.2.1 Perimeter Controls

Perimeter controls will consist of compost filter tubes or straw wattles placed at the limit of work and as indicated on the attached site plans and staked in place with wood stakes. Additional controls that may be used include erosion control matting placed on steep slopes after seeding to prevent erosion. Synthetic mesh may be used for the compost filter tubes or straw wattles. When removal of the erosion controls is warranted, the outer mesh will be cut open and the inner compost or straw material will be distributed on the soil surface or removed and use as a soil amendment elsewhere on the project site. The outer mesh will be

collected and disposed of properly. Use of compost tubes or straw wattles will not be a source for introduction of weed seeds to the project Area.

9.2.2 Catch Basins and Stormwater Quality Units

Siltation sacks will be installed in existing catch basins that are within the project limits. Siltation sacks will be maintained throughout the course of construction activities. Sacks will also be installed in proposed catch basins and maintained until the project is completed. Silt sacks will be inspected and cleaned on a weekly basis or as needed.

9.2.3 Construction Tracking Pad

Stone construction entrances will be installed for access to and from the work site to help control tracking of sediment onto the public streets. Stone construction entrances will be monitored for accumulation of sediment. Before the stone is completely clogged with sediment the construction entrances will be covered with additional stone or completely replaced with new stone to maintain proper function.

9.2.4 Slope Stabilization

The surface of all disturbed areas shall be stabilized during and after construction. Disturbed areas remaining idle for more than 14 days shall be stabilized. Some or all of the following measures will be utilized on this project as conditions may warrant: temporary Seeding, Temporary Mulching, Permanent Seeding, Placement of Sod, Hydroseeding, Placement of Hay, and/or Placement of Jute netting.

Erosion control matting will only be installed if necessary on slopes steeper than 3:1 as the discretion of the StormWater Pollution Prevention(SWPP) inspector. Matting will typically be used as part of the final slope stabilization. Once top soils and seeding of the slope has been completed, matting will be installed to provide additional stabilization of the slope as vegetation. If erosion or gullying is noted, the slope will be regraded and stabilized as needed.

9.2.5 Dust Control

The erosion and sediment control program includes provisions to minimize the generation of dust during dry and windy conditions. Water is the primary method of preventing the generation of fugitive dust. When necessary larger areas of exposed soil will be wetted to prevent wind-borne transport of fine grained sediment. Enough water shall be applied to wet the upper 0.5 inches of soil, but not so much to create surface flow and erosion. The water will be applied as a fine spray to prevent erosion.

9.2.6 Stockpiles

All unused debris, soil, and other material shall be stockpiled in locations of relatively flat grades, away from any trees identified to be saved and upgradient of the perimeter controls. Stockpile side slopes shall not be greater than 2:1. All stockpiles shall be surrounded by a row of haybale and siltation fencing. This shall be inspected and maintained on a consistent basis.

9.3 INSPECTION AND CORRECTIVE ACTION

The following records should be maintained by the operator as part of the SWPPP. See inspection requirements including:

- Dates when major grading activities occur.
- Dates when construction activities temporarily or permanently cease on a portion of the site.
- Dates when stabilization measures are initiated.

Inspections will be every 7 days. Inspection will also be conducted within 24 hours of rain events that exceed 0.25 inches. Copies of Inspection forms are provided in Attachment B.

Once an issue warranting corrective action is identified during the site inspection, it is recorded on the Inspection Report Form. Section A of the Corrective Action Form will also be filled in and provided to the construction personnel responsible. The noted problem must be corrected within 7 days. The problem area will be re-inspected at the next inspection event and Section B of the Corrective Action form will be completed. Corrective Action Form is provided in Attachment B.

Reports summarizing the inspections should be kept as part of the SWPPP. Inspections shall be made of all areas of the site disturbed by construction activities. Inspections must look for evidence of pollutants or potential pollutants entering the stormwater system. Sediment and erosion controls shall be inspected to ensure proper operation. Discharge locations must be inspected to ascertain whether erosion control measures are effective in preventing significant impacts to waters of the United States.

Inspections must be conducted by a properly qualified person. Inspections shall be conducted by persons with knowledge of principles and practices of erosion and sediment control who possess skills to assess conditions at the construction site that could impact stormwater quality and to assess the effectiveness of any sediment and erosion control measures selected to control the quality of stormwater discharges from construction activities.

10.0 LONG-TERM POLLUTION PREVENTION AND OPERATION & MAINTENANCE PLAN

10.1 MAINTENANCE RESPONSIBILITY

Long term maintenance is a key component to the proper functioning of the stormwater system. Ensuring that the system is maintained will ensure proper handling of storm events. After post construction the following measures should be undertaken. The responsibility of the Operation & Maintenance Plan shall be the responsibility of the land owners. This Stormwater O&M plan has been prepared in accordance with Standard 9 of the Massachusetts Department of Environmental Protection (MassDEP) Stormwater Management Standards.

10.2 LITTER & DEBRIS

Trash & litter that collect in the stormwater system can cause potential clogging. Periodic inspection should be made of the area to ensure proper trash & debris removal. Sediment and debris collected from vacuuming and/or sweeping should be disposed of at a permitted waste disposal facility. Avoid disposing of this material on site, where it could be washed into the proposed subsurface infiltration systems.

10.3 ROOF DRAINAGE INFILTRATION FACILITIES

The Infiltration facilities should be inspected after the first several rainfall events and after all major storms. It should be inspected on a quarterly basis (from the inspection port). Water that is found within the chambers after 72 hours of a rainfall indicate the bottom of the system has clogged. The infiltration systems have been placed in grass areas for ease of inspection & maintenance.

10.4 DEEP HOODED SUMP CATCHBASINS

The Catchbasins should be inspected quarterly. All catchbasins should be cleaned twice per year or when sediment in the bottom of the sump reaches to a depth of 24" below the lowest outlet pipe. Catchbasin grates will be kept free from leaves and debris as needed. Grate will also be kept free of ice and snow. Two inspections should be performed at the start and finish of the winter months.

10.5 PARKING LOT SWEEPING

Parking lot sweeping shall be performed at least once per year at the end of the winter season. Cleaning of the Deep Hooded Sump Catchbasins shall be performed in coordination with this plan.

10.6 SOLID WASTE

All Solid waste shall be confined to closable and secured containers and shall be disposed of in accordance with all Local & State regulations.

10.7 MAINTENANCE OF LANDSCAPED AREAS

Grass and mulch clippings should be left as natural fertilizers. Whenever possible natural fertilizers should be used. Watering should be low volume to prevent runoff problems. Do not fertilize prior to a rainfall event. Store fertilizers in a manner recommended by the manufacturer. Storage shall be in a covered area or shed.

10.8 SNOW STORAGE

Plowed snow shall be pushed or stored in a designated snow storage area. All Catchbasins and manholes are to be cleared of snow. Snow shall not be stored in the infiltration basins. Snow shall not be stored in or near a wetland resource area. Melted snow debris (sand/salt) shall be removed from the site and properly disposed.

10.9 SALT & SAND STORAGE

Salt & Sand storage shall follow MGL. Ch.85 Sec 7A. Storage and use of snow removal chemicals, regulations, reports, penalty

10.10 GOOD HOUSEKEEPING

The site is always to be kept clean of trash and debris. Trash, junk, etc. is not to be left outside and will be subject to removal at the owner's expense. Records shall be maintained and kept by the owner at their offices as described above and shall document all maintenance to the stormwater management system and shall bear the signature of the individual supervising the work. See Attachment C for template.

11.0 DEP CHECKLIST FOR STORMWATER REPORT



Checklist for Stormwater Report

A. Introduction

Important: When filling out forms on the computer, use only the tab key to move your cursor - do not use the return key.



A Stormwater Report must be submitted with the Notice of Intent permit application to document compliance with the Stormwater Management Standards. The following checklist is NOT a substitute for the Stormwater Report (which should provide more substantive and detailed information) but is offered here as a tool to help the applicant organize their Stormwater Management documentation for their Report and for the reviewer to assess this information in a consistent format. As noted in the Checklist, the Stormwater Report must contain the engineering computations and supporting information set forth in Volume 3 of the [Massachusetts Stormwater Handbook](#). The Stormwater Report must be prepared and certified by a Registered Professional Engineer (RPE) licensed in the Commonwealth.

The Stormwater Report must include:

- The Stormwater Checklist completed and stamped by a Registered Professional Engineer (see page 2) that certifies that the Stormwater Report contains all required submittals.¹ This Checklist is to be used as the cover for the completed Stormwater Report.
- Applicant/Project Name
- Project Address
- Name of Firm and Registered Professional Engineer that prepared the Report
- Long-Term Pollution Prevention Plan required by Standards 4-6
- Construction Period Pollution Prevention and Erosion and Sedimentation Control Plan required by Standard 8²
- Operation and Maintenance Plan required by Standard 9

In addition to all plans and supporting information, the Stormwater Report must include a brief narrative describing stormwater management practices, including environmentally sensitive site design and LID techniques, along with a diagram depicting runoff through the proposed BMP treatment train. Plans are required to show existing and proposed conditions, identify all wetland resource areas, NRCS soil types, critical areas, Land Uses with Higher Potential Pollutant Loads (LUHPPL), and any areas on the site where infiltration rate is greater than 2.4 inches per hour. The Plans shall identify the drainage areas for both existing and proposed conditions at a scale that enables verification of supporting calculations.

As noted in the Checklist, the Stormwater Management Report shall document compliance with each of the Stormwater Management Standards as provided in the Massachusetts Stormwater Handbook. The soils evaluation and calculations shall be done using the methodologies set forth in Volume 3 of the Massachusetts Stormwater Handbook.

To ensure that the Stormwater Report is complete, applicants are required to fill in the Stormwater Report Checklist by checking the box to indicate that the specified information has been included in the Stormwater Report. If any of the information specified in the checklist has not been submitted, the applicant must provide an explanation. The completed Stormwater Report Checklist and Certification must be submitted with the Stormwater Report.

¹ The Stormwater Report may also include the Illicit Discharge Compliance Statement required by Standard 10. If not included in the Stormwater Report, the Illicit Discharge Compliance Statement must be submitted prior to the discharge of stormwater runoff to the post-construction best management practices.

² For some complex projects, it may not be possible to include the Construction Period Erosion and Sedimentation Control Plan in the Stormwater Report. In that event, the issuing authority has the discretion to issue an Order of Conditions that approves the project and includes a condition requiring the proponent to submit the Construction Period Erosion and Sedimentation Control Plan before commencing any land disturbance activity on the site.



Checklist for Stormwater Report

B. Stormwater Checklist and Certification

The following checklist is intended to serve as a guide for applicants as to the elements that ordinarily need to be addressed in a complete Stormwater Report. The checklist is also intended to provide conservation commissions and other reviewing authorities with a summary of the components necessary for a comprehensive Stormwater Report that addresses the ten Stormwater Standards.

Note: Because stormwater requirements vary from project to project, it is possible that a complete Stormwater Report may not include information on some of the subjects specified in the Checklist. If it is determined that a specific item does not apply to the project under review, please note that the item is not applicable (N.A.) and provide the reasons for that determination.

A complete checklist must include the Certification set forth below signed by the Registered Professional Engineer who prepared the Stormwater Report.

Registered Professional Engineer's Certification

I have reviewed the Stormwater Report, including the soil evaluation, computations, Long-term Pollution Prevention Plan, the Construction Period Erosion and Sedimentation Control Plan (if included), the Long-term Post-Construction Operation and Maintenance Plan, the Illicit Discharge Compliance Statement (if included) and the plans showing the stormwater management system, and have determined that they have been prepared in accordance with the requirements of the Stormwater Management Standards as further elaborated by the Massachusetts Stormwater Handbook. I have also determined that the information presented in the Stormwater Checklist is accurate and that the information presented in the Stormwater Report accurately reflects conditions at the site as of the date of this permit application.

Registered Professional Engineer Block and Signature

Signature and Date

Checklist

Project Type: Is the application for new development, redevelopment, or a mix of new and redevelopment?

- New development
- Redevelopment
- Mix of New Development and Redevelopment



Checklist for Stormwater Report

Checklist (continued)

LID Measures: Stormwater Standards require LID measures to be considered. Document what environmentally sensitive design and LID Techniques were considered during the planning and design of the project:

- No disturbance to any Wetland Resource Areas
- Site Design Practices (e.g. clustered development, reduced frontage setbacks)
- Reduced Impervious Area (Redevelopment Only)
- Minimizing disturbance to existing trees and shrubs
- LID Site Design Credit Requested:
 - Credit 1
 - Credit 2
 - Credit 3
- Use of "country drainage" versus curb and gutter conveyance and pipe
- Bioretention Cells (includes Rain Gardens)
- Constructed Stormwater Wetlands (includes Gravel Wetlands designs)
- Treebox Filter
- Water Quality Swale
- Grass Channel
- Green Roof
- Other (describe): _____

Standard 1: No New Untreated Discharges

- No new untreated discharges
- Outlets have been designed so there is no erosion or scour to wetlands and waters of the Commonwealth
- Supporting calculations specified in Volume 3 of the Massachusetts Stormwater Handbook included.



Checklist for Stormwater Report

Checklist (continued)

Standard 2: Peak Rate Attenuation

- Standard 2 waiver requested because the project is located in land subject to coastal storm flowage and stormwater discharge is to a wetland subject to coastal flooding.
- Evaluation provided to determine whether off-site flooding increases during the 100-year 24-hour storm.
- Calculations provided to show that post-development peak discharge rates do not exceed pre-development rates for the 2-year and 10-year 24-hour storms. If evaluation shows that off-site flooding increases during the 100-year 24-hour storm, calculations are also provided to show that post-development peak discharge rates do not exceed pre-development rates for the 100-year 24-hour storm.

Standard 3: Recharge

- Soil Analysis provided.
- Required Recharge Volume calculation provided.
- Required Recharge volume reduced through use of the LID site Design Credits.
- Sizing the infiltration, BMPs is based on the following method: Check the method used.
 - Static
 - Simple Dynamic
 - Dynamic Field¹
- Runoff from all impervious areas at the site discharging to the infiltration BMP.
- Runoff from all impervious areas at the site is *not* discharging to the infiltration BMP and calculations are provided showing that the drainage area contributing runoff to the infiltration BMPs is sufficient to generate the required recharge volume.
- Recharge BMPs have been sized to infiltrate the Required Recharge Volume.
- Recharge BMPs have been sized to infiltrate the Required Recharge Volume *only* to the maximum extent practicable for the following reason:
 - Site is comprised solely of C and D soils and/or bedrock at the land surface
 - M.G.L. c. 21E sites pursuant to 310 CMR 40.0000
 - Solid Waste Landfill pursuant to 310 CMR 19.000
 - Project is otherwise subject to Stormwater Management Standards only to the maximum extent practicable.
- Calculations showing that the infiltration BMPs will drain in 72 hours are provided.
- Property includes a M.G.L. c. 21E site or a solid waste landfill and a mounding analysis is included.

¹ 80% TSS removal is required prior to discharge to infiltration BMP if Dynamic Field method is used.



Checklist for Stormwater Report

Checklist (continued)

Standard 3: Recharge (continued)

- The infiltration BMP is used to attenuate peak flows during storms greater than or equal to the 10-year 24-hour storm and separation to seasonal high groundwater is less than 4 feet and a mounding analysis is provided.
- Documentation is provided showing that infiltration BMPs do not adversely impact nearby wetland resource areas.

Standard 4: Water Quality

The Long-Term Pollution Prevention Plan typically includes the following:

- Good housekeeping practices;
 - Provisions for storing materials and waste products inside or under cover;
 - Vehicle washing controls;
 - Requirements for routine inspections and maintenance of stormwater BMPs;
 - Spill prevention and response plans;
 - Provisions for maintenance of lawns, gardens, and other landscaped areas;
 - Requirements for storage and use of fertilizers, herbicides, and pesticides;
 - Pet waste management provisions;
 - Provisions for operation and management of septic systems;
 - Provisions for solid waste management;
 - Snow disposal and plowing plans relative to Wetland Resource Areas;
 - Winter Road Salt and/or Sand Use and Storage restrictions;
 - Street sweeping schedules;
 - Provisions for prevention of illicit discharges to the stormwater management system;
 - Documentation that Stormwater BMPs are designed to provide for shutdown and containment in the event of a spill or discharges to or near critical areas or from LUHPPL;
 - Training for staff or personnel involved with implementing Long-Term Pollution Prevention Plan;
 - List of Emergency contacts for implementing Long-Term Pollution Prevention Plan.
- A Long-Term Pollution Prevention Plan is attached to Stormwater Report and is included as an attachment to the Wetlands Notice of Intent.
 - Treatment BMPs subject to the 44% TSS removal pretreatment requirement and the one inch rule for calculating the water quality volume are included, and discharge:
 - is within the Zone II or Interim Wellhead Protection Area
 - is near or to other critical areas
 - is within soils with a rapid infiltration rate (greater than 2.4 inches per hour)
 - involves runoff from land uses with higher potential pollutant loads.
 - The Required Water Quality Volume is reduced through use of the LID site Design Credits.
 - Calculations documenting that the treatment train meets the 80% TSS removal requirement and, if applicable, the 44% TSS removal pretreatment requirement, are provided.



Checklist for Stormwater Report

Checklist (continued)

Standard 4: Water Quality (continued)

- The BMP is sized (and calculations provided) based on:
 - The ½" or 1" Water Quality Volume or
 - The equivalent flow rate associated with the Water Quality Volume and documentation is provided showing that the BMP treats the required water quality volume.
- The applicant proposes to use proprietary BMPs, and documentation supporting use of proprietary BMP and proposed TSS removal rate is provided. This documentation may be in the form of the propriety BMP checklist found in Volume 2, Chapter 4 of the Massachusetts Stormwater Handbook and submitting copies of the TARP Report, STEP Report, and/or other third party studies verifying performance of the proprietary BMPs.
- A TMDL exists that indicates a need to reduce pollutants other than TSS and documentation showing that the BMPs selected are consistent with the TMDL is provided.

Standard 5: Land Uses With Higher Potential Pollutant Loads (LUHPPLs)

- The NPDES Multi-Sector General Permit covers the land use and the Stormwater Pollution Prevention Plan (SWPPP) has been included with the Stormwater Report.
- The NPDES Multi-Sector General Permit covers the land use and the SWPPP will be submitted **prior to** the discharge of stormwater to the post-construction stormwater BMPs.
- The NPDES Multi-Sector General Permit does **not** cover the land use.
- LUHPPLs are located at the site and industry specific source control and pollution prevention measures have been proposed to reduce or eliminate the exposure of LUHPPLs to rain, snow, snow melt and runoff, and been included in the long term Pollution Prevention Plan.
- All exposure has been eliminated.
- All exposure has **not** been eliminated and all BMPs selected are on MassDEP LUHPPL list.
- The LUHPPL has the potential to generate runoff with moderate to higher concentrations of oil and grease (e.g. all parking lots with >1000 vehicle trips per day) and the treatment train includes an oil grit separator, a filtering bioretention area, a sand filter or equivalent.

Standard 6: Critical Areas

- The discharge is near or to a critical area and the treatment train includes only BMPs that MassDEP has approved for stormwater discharges to or near that particular class of critical area.
- Critical areas and BMPs are identified in the Stormwater Report.



Checklist for Stormwater Report

Checklist (continued)

Standard 7: Redevelopments and Other Projects Subject to the Standards only to the maximum extent practicable

- The project is subject to the Stormwater Management Standards only to the maximum Extent Practicable as a:
 - Limited Project
 - Small Residential Projects: 5-9 single family houses or 5-9 units in a multi-family development provided there is no discharge that may potentially affect a critical area.
 - Small Residential Projects: 2-4 single family houses or 2-4 units in a multi-family development with a discharge to a critical area
 - Marina and/or boatyard provided the hull painting, service and maintenance areas are protected from exposure to rain, snow, snow melt and runoff
 - Bike Path and/or Foot Path
 - Redevelopment Project
 - Redevelopment portion of mix of new and redevelopment.
- Certain standards are not fully met (Standard No. 1, 8, 9, and 10 must always be fully met) and an explanation of why these standards are not met is contained in the Stormwater Report.
- The project involves redevelopment and a description of all measures that have been taken to improve existing conditions is provided in the Stormwater Report. The redevelopment checklist found in Volume 2 Chapter 3 of the Massachusetts Stormwater Handbook may be used to document that the proposed stormwater management system (a) complies with Standards 2, 3 and the pretreatment and structural BMP requirements of Standards 4-6 to the maximum extent practicable and (b) improves existing conditions.

Standard 8: Construction Period Pollution Prevention and Erosion and Sedimentation Control

A Construction Period Pollution Prevention and Erosion and Sedimentation Control Plan must include the following information:

- Narrative;
 - Construction Period Operation and Maintenance Plan;
 - Names of Persons or Entity Responsible for Plan Compliance;
 - Construction Period Pollution Prevention Measures;
 - Erosion and Sedimentation Control Plan Drawings;
 - Detail drawings and specifications for erosion control BMPs, including sizing calculations;
 - Vegetation Planning;
 - Site Development Plan;
 - Construction Sequencing Plan;
 - Sequencing of Erosion and Sedimentation Controls;
 - Operation and Maintenance of Erosion and Sedimentation Controls;
 - Inspection Schedule;
 - Maintenance Schedule;
 - Inspection and Maintenance Log Form.
- A Construction Period Pollution Prevention and Erosion and Sedimentation Control Plan containing the information set forth above has been included in the Stormwater Report.



Checklist for Stormwater Report

Checklist (continued)

Standard 8: Construction Period Pollution Prevention and Erosion and Sedimentation Control (continued)

- The project is highly complex and information is included in the Stormwater Report that explains why it is not possible to submit the Construction Period Pollution Prevention and Erosion and Sedimentation Control Plan with the application. A Construction Period Pollution Prevention and Erosion and Sedimentation Control has **not** been included in the Stormwater Report but will be submitted **before** land disturbance begins.
- The project is **not** covered by a NPDES Construction General Permit.
- The project is covered by a NPDES Construction General Permit and a copy of the SWPPP is in the Stormwater Report.
- The project is covered by a NPDES Construction General Permit but no SWPPP been submitted. The SWPPP will be submitted BEFORE land disturbance begins.

Standard 9: Operation and Maintenance Plan

- The Post Construction Operation and Maintenance Plan is included in the Stormwater Report and includes the following information:
 - Name of the stormwater management system owners;
 - Party responsible for operation and maintenance;
 - Schedule for implementation of routine and non-routine maintenance tasks;
 - Plan showing the location of all stormwater BMPs maintenance access areas;
 - Description and delineation of public safety features;
 - Estimated operation and maintenance budget; and
 - Operation and Maintenance Log Form.
- The responsible party is **not** the owner of the parcel where the BMP is located and the Stormwater Report includes the following submissions:
 - A copy of the legal instrument (deed, homeowner's association, utility trust or other legal entity) that establishes the terms of and legal responsibility for the operation and maintenance of the project site stormwater BMPs;
 - A plan and easement deed that allows site access for the legal entity to operate and maintain BMP functions.

Standard 10: Prohibition of Illicit Discharges

- The Long-Term Pollution Prevention Plan includes measures to prevent illicit discharges;
- An Illicit Discharge Compliance Statement is attached;
- NO Illicit Discharge Compliance Statement is attached but will be submitted **prior to** the discharge of any stormwater to post-construction BMPs.

12.0 ILLICIT DISCHARGE COMPLIANCE STATEMENT

Massachusetts Stormwater Standards

Standard 10 - Illicit Discharge Compliance Statement

Site Address: #0 Meadowbrook St. Worcester, MA 01609

Owner Applicant: Buckingham Development, LLC

Plan Reference: 0 Meadowbrook Amendment to Definitive Site Plan

As required by Standard 10 of the Massachusetts Stormwater Standards, I, the undersigned, being the Owner of the subject property do hereby certify that the stormwater system, as shown on the referenced plan, does not permit any illicit discharges to enter the stormwater management system. I also certify that the existing use of the property does not permit any illicit discharges.

Illicit discharges are discharges not associated with the following: stormwater; water from fire fighting; water line flushing or street washing; landscape watering and irrigation; uncontaminated groundwater; potable water; foundation or footing drains; air conditioning condensate; residential vehicle washing ; residential non-detergent building cleaning water; de-chlorinated water from swimming pools, flows from riparian habitats or wetlands.

Further, I certify that the stormwater management system shown on the referenced plan will be maintained in accordance with the Operations & Maintenance Provisions of the Stormwater report dated April 18, 2019.

Signed: _____

Print Name: _____ Date: _____
Owner or Authorized Applicant

APPENDICIES

- A. NRCS SOILS SURVEY & MAP
- B. FLOOD INSURANCE RATE MAP
- C. USGS QUAD MAP
- D. TSS REMOVAL WORKSHEET

Drainage Class—Worcester County, Massachusetts, Northeastern Part

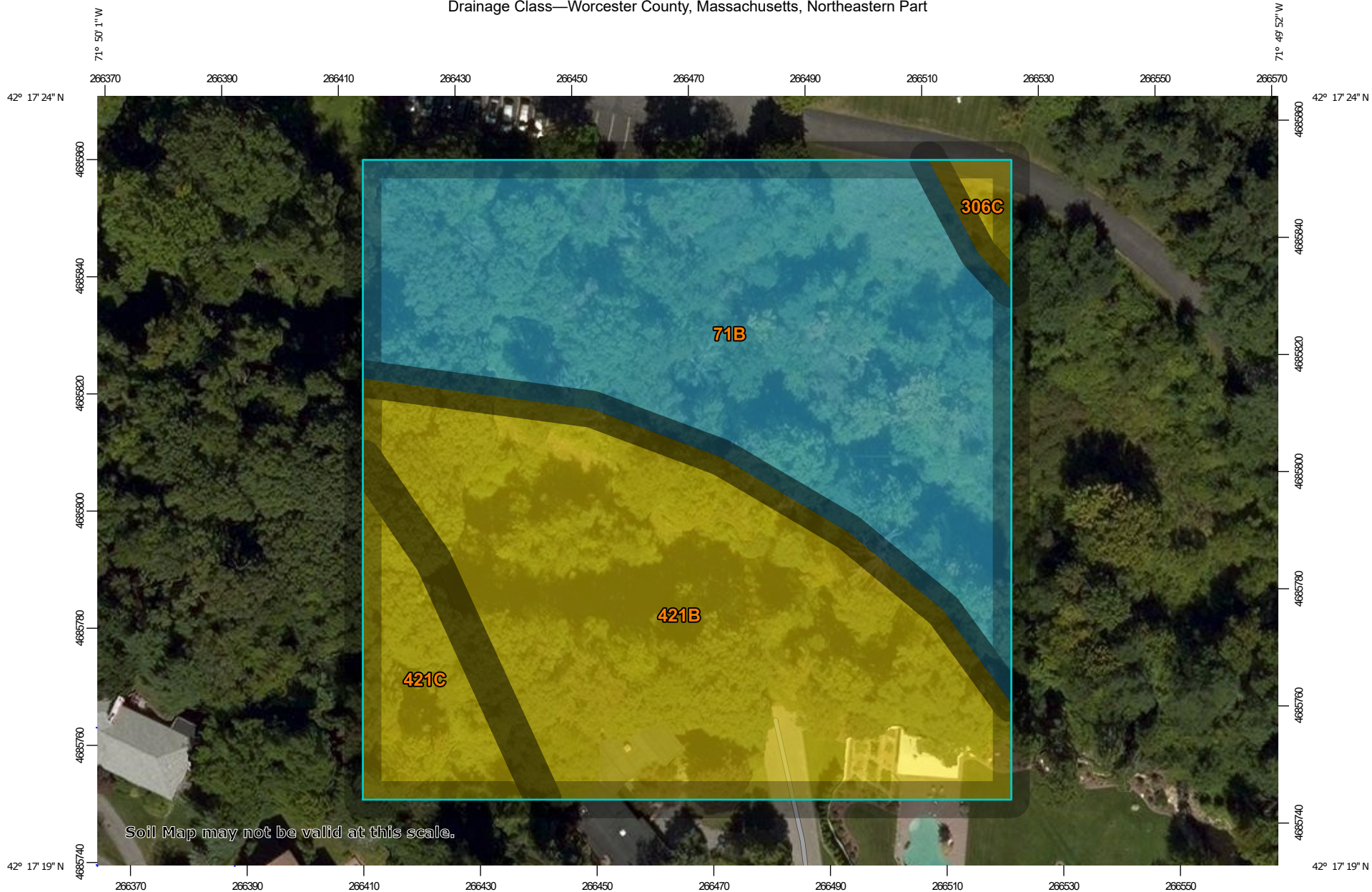

Soil Map may not be valid at this scale.

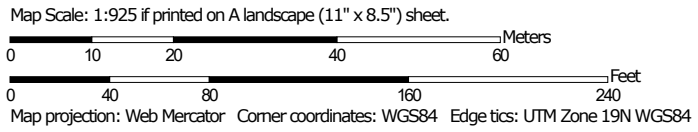



MAP LEGEND

Area of Interest (AOI)

 Area of Interest (AOI)

Soils

Soil Rating Polygons

-  Excessively drained
-  Somewhat excessively drained
-  Well drained
-  Moderately well drained
-  Somewhat poorly drained
-  Poorly drained
-  Very poorly drained
-  Subaqueous
-  Not rated or not available

Soil Rating Lines

-  Excessively drained
-  Somewhat excessively drained
-  Well drained
-  Moderately well drained
-  Somewhat poorly drained
-  Poorly drained
-  Very poorly drained
-  Subaqueous
-  Not rated or not available





Soil Rating Points

-  Excessively drained
-  Somewhat excessively drained
-  Well drained
-  Moderately well drained
-  Somewhat poorly drained
-  Poorly drained
-  Very poorly drained
-  Subaqueous
-  Not rated or not available

Water Features

 Streams and Canals

Transportation

-  Rails
-  Interstate Highways
-  US Routes
-  Major Roads
-  Local Roads

Background

 Aerial Photography

MAP INFORMATION

The soil surveys that comprise your AOI were mapped at 1:20,000.

Warning: Soil Map may not be valid at this scale.

Enlargement of maps beyond the scale of mapping can cause misunderstanding of the detail of mapping and accuracy of soil line placement. The maps do not show the small areas of contrasting soils that could have been shown at a more detailed scale.

Please rely on the bar scale on each map sheet for map measurements.

Source of Map: Natural Resources Conservation Service
 Web Soil Survey URL:
 Coordinate System: Web Mercator (EPSG:3857)

Maps from the Web Soil Survey are based on the Web Mercator projection, which preserves direction and shape but distorts distance and area. A projection that preserves area, such as the Albers equal-area conic projection, should be used if more accurate calculations of distance or area are required.

This product is generated from the USDA-NRCS certified data as of the version date(s) listed below.

Soil Survey Area: Worcester County, Massachusetts, Northeastern Part
 Survey Area Data: Version 14, Sep 13, 2019

Soil map units are labeled (as space allows) for map scales 1:50,000 or larger.

Date(s) aerial images were photographed: Sep 12, 2014—Sep 28, 2014

The orthophoto or other base map on which the soil lines were compiled and digitized probably differs from the background imagery displayed on these maps. As a result, some minor shifting of map unit boundaries may be evident.

Drainage Class

Map unit symbol	Map unit name	Rating	Acres in AOI	Percent of AOI
71B	Ridgebury fine sandy loam, 3 to 8 percent slopes, extremely stony	Poorly drained	1.4	47.8%
306C	Paxton fine sandy loam, 8 to 15 percent slopes, very stony	Well drained	0.0	1.4%
421B	Canton fine sandy loam, 0 to 8 percent slopes, very stony	Well drained	1.3	42.6%
421C	Canton fine sandy loam, 8 to 15 percent slopes, very stony	Well drained	0.2	8.1%
Totals for Area of Interest			3.0	100.0%

Description

"Drainage class (natural)" refers to the frequency and duration of wet periods under conditions similar to those under which the soil formed. Alterations of the water regime by human activities, either through drainage or irrigation, are not a consideration unless they have significantly changed the morphology of the soil. Seven classes of natural soil drainage are recognized-excessively drained, somewhat excessively drained, well drained, moderately well drained, somewhat poorly drained, poorly drained, and very poorly drained. These classes are defined in the "Soil Survey Manual."

Rating Options

Aggregation Method: Dominant Condition

Component Percent Cutoff: None Specified

Tie-break Rule: Higher

National Flood Hazard Layer FIRMette



42°17'29.70"N

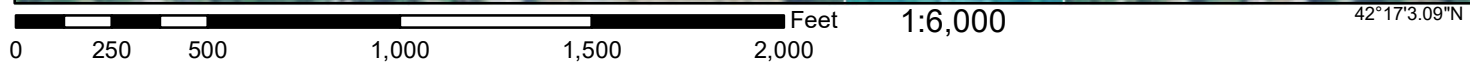
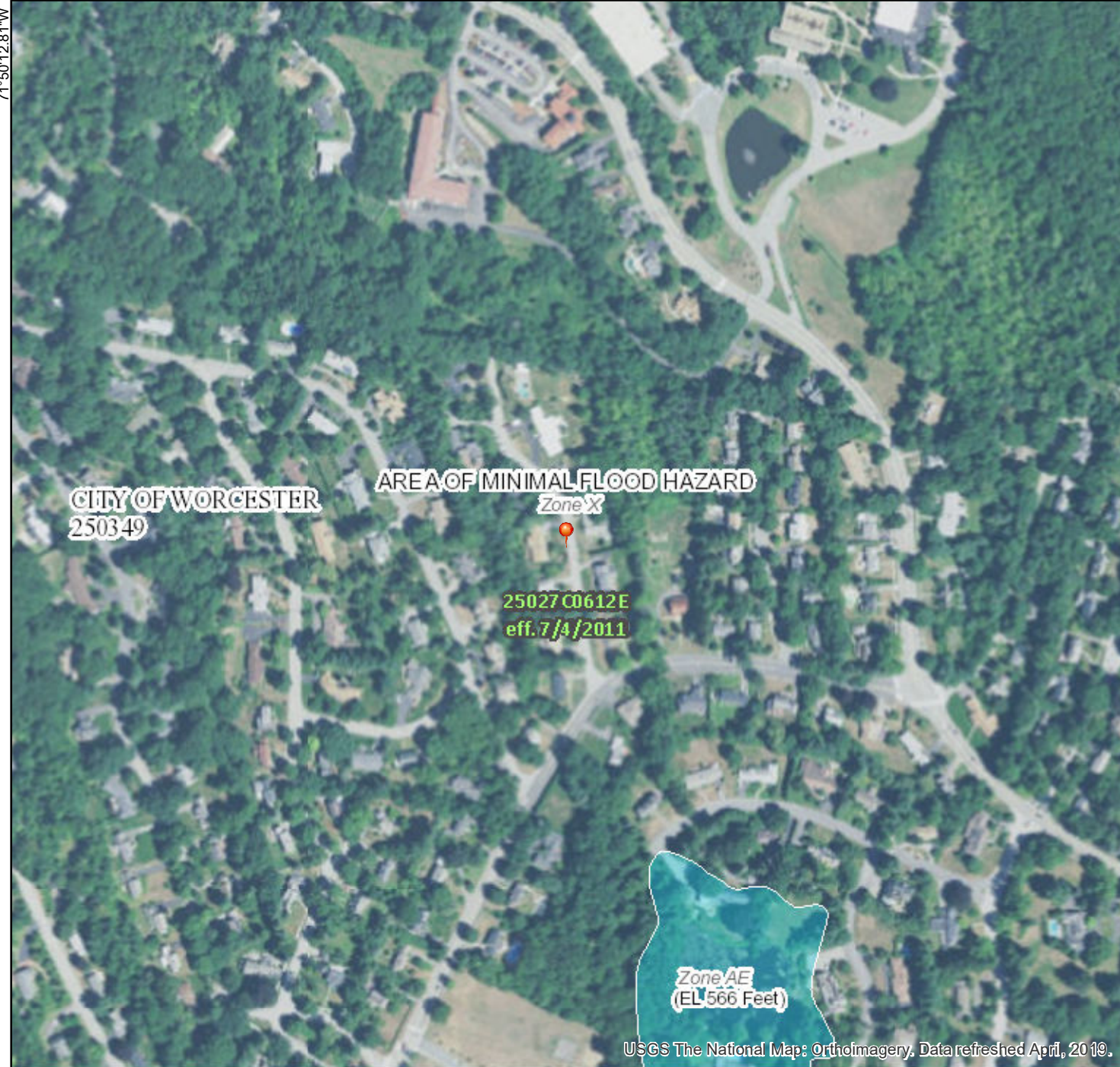

Legend

SEE FIS REPORT FOR DETAILED LEGEND AND INDEX MAP FOR FIRM PANEL LAYOUT

SPECIAL FLOOD HAZARD AREAS		Without Base Flood Elevation (BFE) <i>Zone A, V, A99</i>
		With BFE or Depth <i>Zone AE, AO, AH, VE, AR</i>
		Regulatory Floodway

OTHER AREAS OF FLOOD HAZARD		0.2% Annual Chance Flood Hazard, Areas of 1% annual chance flood with average depth less than one foot or with drainage areas of less than one square mile <i>Zone X</i>
		Future Conditions 1% Annual Chance Flood Hazard <i>Zone X</i>
		Area with Reduced Flood Risk due to Levee. See Notes. <i>Zone X</i>
		Area with Flood Risk due to Levee <i>Zone D</i>

OTHER AREAS		NO SCREEN Area of Minimal Flood Hazard <i>Zone X</i>
		Effective LOMRs
		Area of Undetermined Flood Hazard <i>Zone D</i>

GENERAL STRUCTURES		Channel, Culvert, or Storm Sewer
		Levee, Dike, or Floodwall

OTHER FEATURES		20.2 Cross Sections with 1% Annual Chance
		17.5 Water Surface Elevation
		Coastal Transect
		Base Flood Elevation Line (BFE)
		Limit of Study
		Jurisdiction Boundary
OTHER FEATURES		Coastal Transect Baseline
		Profile Baseline
		Hydrographic Feature

MAP PANELS		Digital Data Available
		No Digital Data Available
		Unmapped

The pin displayed on the map is an approximate point selected by the user and does not represent an authoritative property location.

This map complies with FEMA's standards for the use of digital flood maps if it is not void as described below. The basemap shown complies with FEMA's basemap accuracy standards

The flood hazard information is derived directly from the authoritative NFHL web services provided by FEMA. This map was exported on 2/3/2020 at 10:31:40 PM and does not reflect changes or amendments subsequent to this date and time. The NFHL and effective information may change or become superseded by new data over time.

This map image is void if the one or more of the following map elements do not appear: basemap imagery, flood zone labels, legend, scale bar, map creation date, community identifiers, FIRM panel number, and FIRM effective date. Map images for unmapped and unmodernized areas cannot be used for regulatory purposes.

71°50'12.81"W

71°49'35.35"W

USGS The National Map: Orthoimagery, Data refreshed April, 2019.

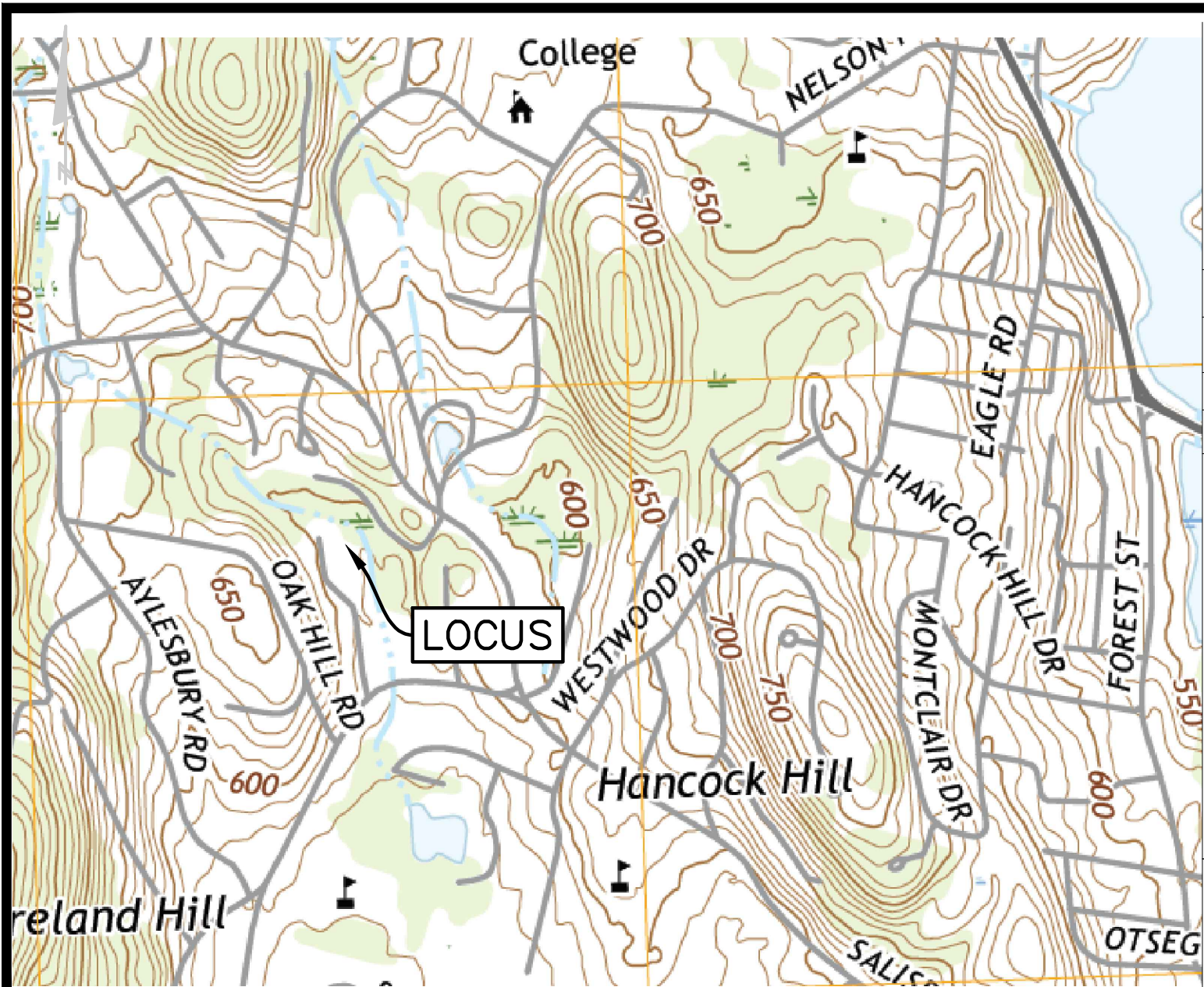

USGS LOCUS MAP

**#0 MEADOWBROOK
WORCESTER, MA**

OWNED BY:

BUCKINGHAM DEVELOPMENT
LLC

REVISION: REV 0	DATE: 2/02/2020
--------------------	--------------------

REVISION:	DATE:
-----------	-------

DRAWN BY:	JRG
-----------	-----

SCALE:	1"=1000'
--------	----------

LOCUS

PREPARED BY:

ROBERT D. O'NEIL JR.

66 DRURY LANE
WORCESTER, MA
TEL/FAX: (508) 755-3513

INSTRUCTIONS:

1. In BMP Column, click on Blue Cell to Activate Drop Down Menu
2. Select BMP from Drop Down Menu
3. After BMP is selected, TSS Removal and other Columns are automatically completed.

Version 1, Automated: Mar. 4, 2008

Location: 0 Meadowbrook St Worcester, MA 01609

TSS Removal Calculation Worksheet

B BMP ¹	C TSS Removal Rate ¹	D Starting TSS Load*	E Amount Removed (C*D)	F Remaining Load (D-E)
Street Sweeping - 1%	0.01	1.00	0.01	0.99
Deep Sump and Hooded Catch Basin	0.25	0.99	0.25	0.74
Sediment Forebay	0.25	0.74	0.19	0.56
Water Quality Swale - Dry	0.70	0.56	0.39	0.17
	0.00	0.17	0.00	0.17

Total TSS Removal =

83%

Separate Form Needs to be Completed for Each Outlet or BMP Train

Project: 0 Meadowbrook
 Prepared By: Joseph Graham, P.E.
 Date: 2/2/2020

*Equals remaining load from previous BMP (E) which enters the BMP

ATTACHMENTS

- A. SITE PLAN PERMITTING SHEET SET
- B. SWPPP INSPECTION AND CORRECTIVE ACTION FORMS
- C. LONG-TERM OPERATION AND MAINTENANCE LOG

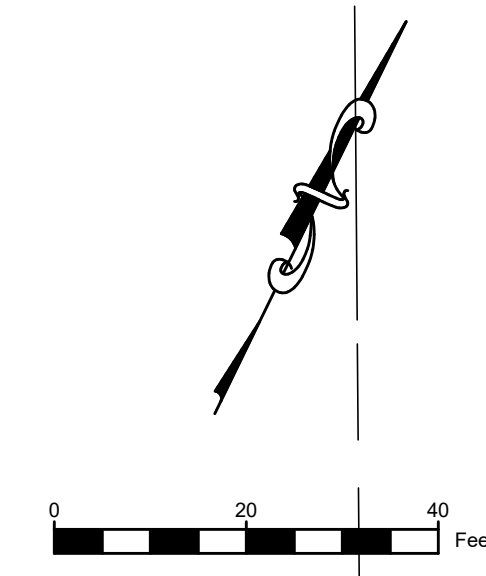
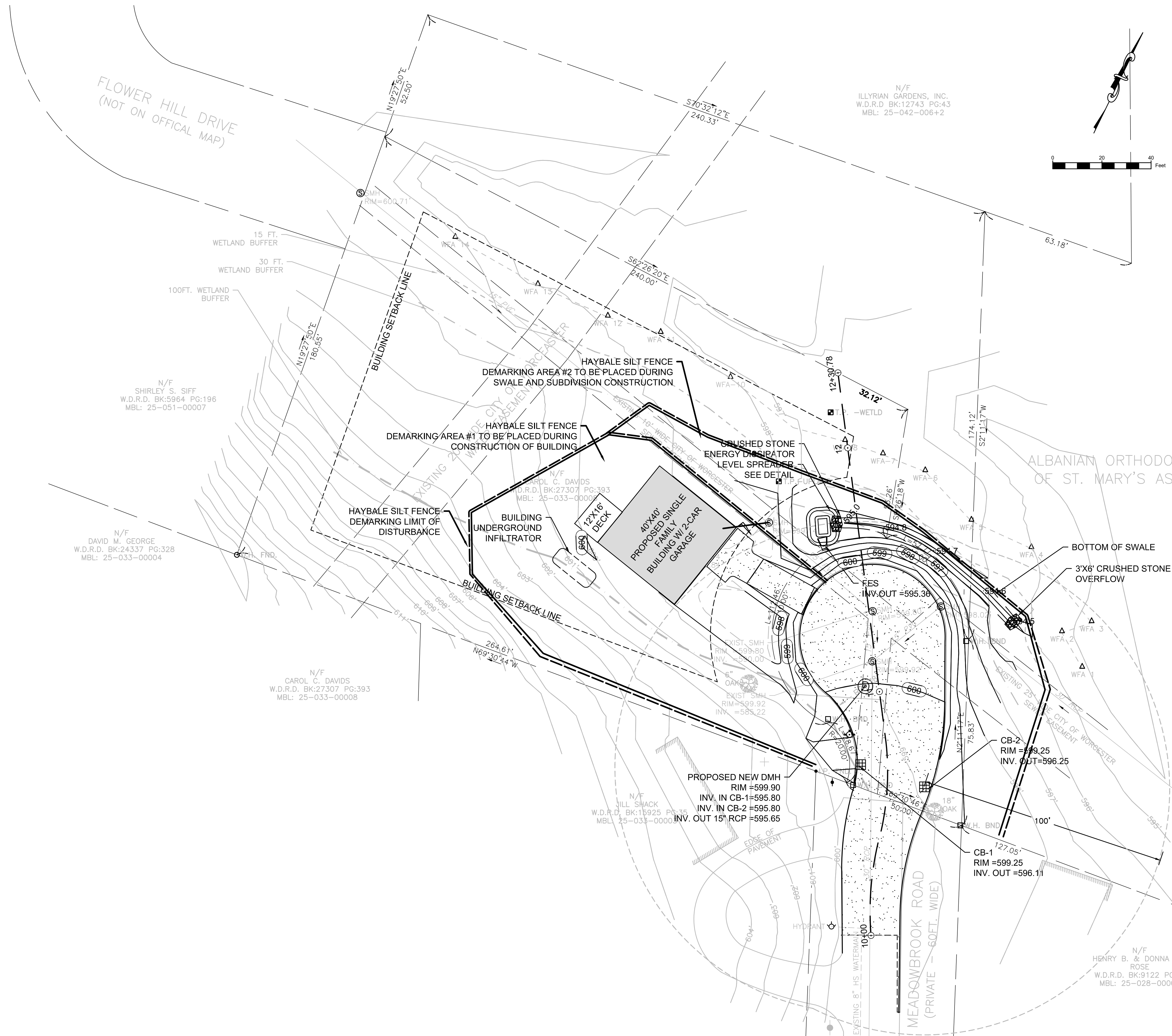

Project 0 MEADOWBROOK																	
Date 4/30/19																	
Scale 1" = 20'																	
General Notes																	
<table border="1" style="width: 100%; border-collapse: collapse;"> <tr> <td style="width: 5%;"></td> <td style="width: 85%;">- EROS. CNTRL PLAN</td> <td style="width: 10%;">4/30/19</td> </tr> <tr> <th>No.</th> <th>Revision/Issue</th> <th>Date</th> </tr> <tr> <td> </td> <td> </td> <td> </td> </tr> </table>				- EROS. CNTRL PLAN	4/30/19	No.	Revision/Issue	Date									
	- EROS. CNTRL PLAN	4/30/19															
No.	Revision/Issue	Date															
<table border="1" style="width: 100%; border-collapse: collapse;"> <tr> <td colspan="3">Firm Name and Address</td> </tr> <tr> <td colspan="3" style="text-align: center;">Joseph Graham, PE</td> </tr> <tr> <td colspan="3" style="text-align: center;">119 Pike St.</td> </tr> <tr> <td colspan="3" style="text-align: center;">Tewksbury, MA 01876</td> </tr> <tr> <td colspan="3" style="text-align: center;">(978) 501.2695</td> </tr> </table>			Firm Name and Address			Joseph Graham, PE			119 Pike St.			Tewksbury, MA 01876			(978) 501.2695		
Firm Name and Address																	
Joseph Graham, PE																	
119 Pike St.																	
Tewksbury, MA 01876																	
(978) 501.2695																	
<table border="1" style="width: 100%; border-collapse: collapse;"> <tr> <td colspan="3">Project Name and Address</td> </tr> <tr> <td colspan="3">SITE PLAN RECREATION</td> </tr> <tr> <td colspan="3">0 MEADOWBROOK</td> </tr> <tr> <td colspan="3">Worcester, MA 01607</td> </tr> </table>			Project Name and Address			SITE PLAN RECREATION			0 MEADOWBROOK			Worcester, MA 01607					
Project Name and Address																	
SITE PLAN RECREATION																	
0 MEADOWBROOK																	
Worcester, MA 01607																	
<table border="1" style="width: 100%; border-collapse: collapse;"> <tr> <td colspan="3">Sheet</td> </tr> <tr> <td colspan="3" style="text-align: center; font-size: 2em;">4</td> </tr> </table>			Sheet			4											
Sheet																	
4																	

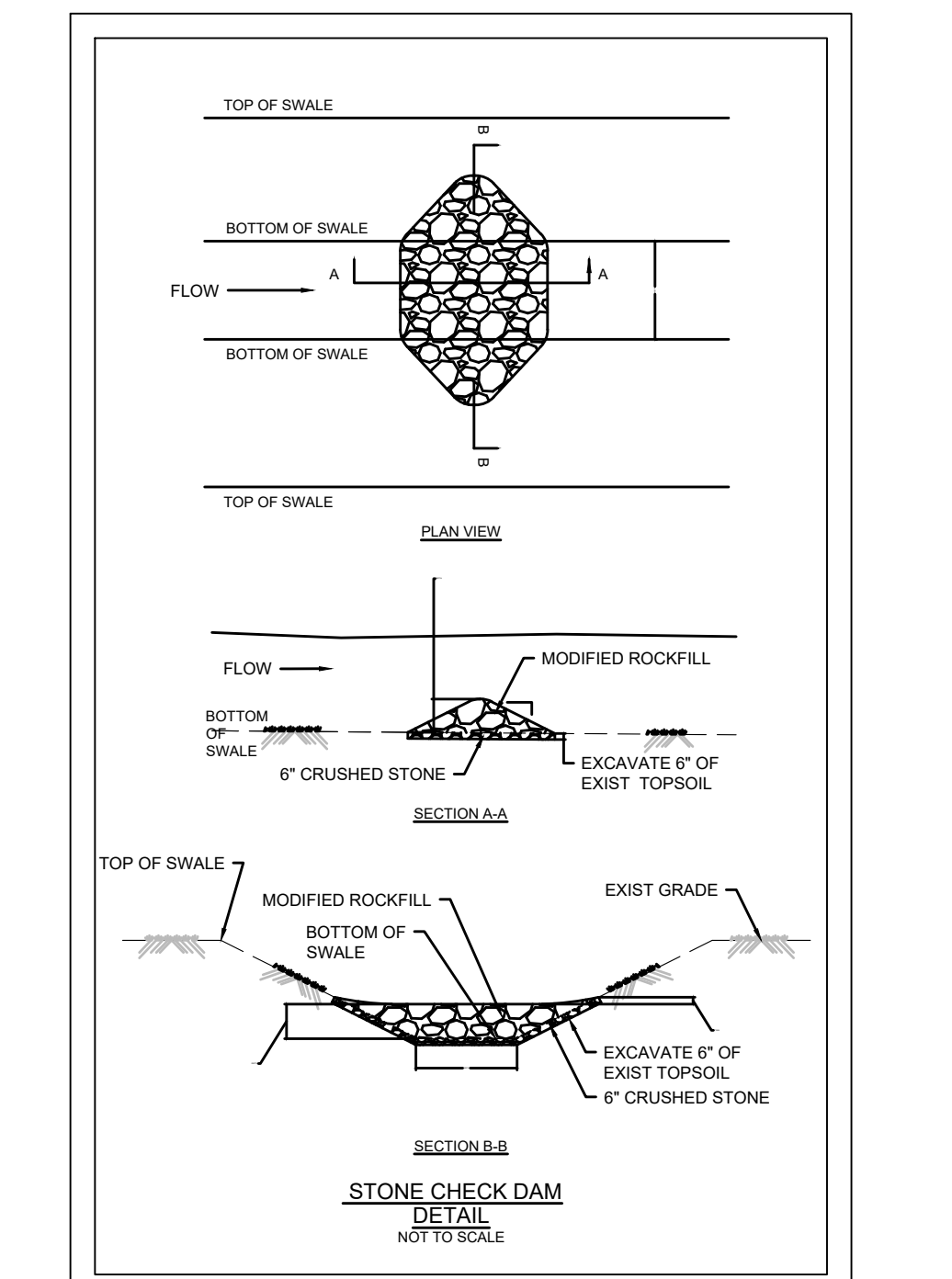
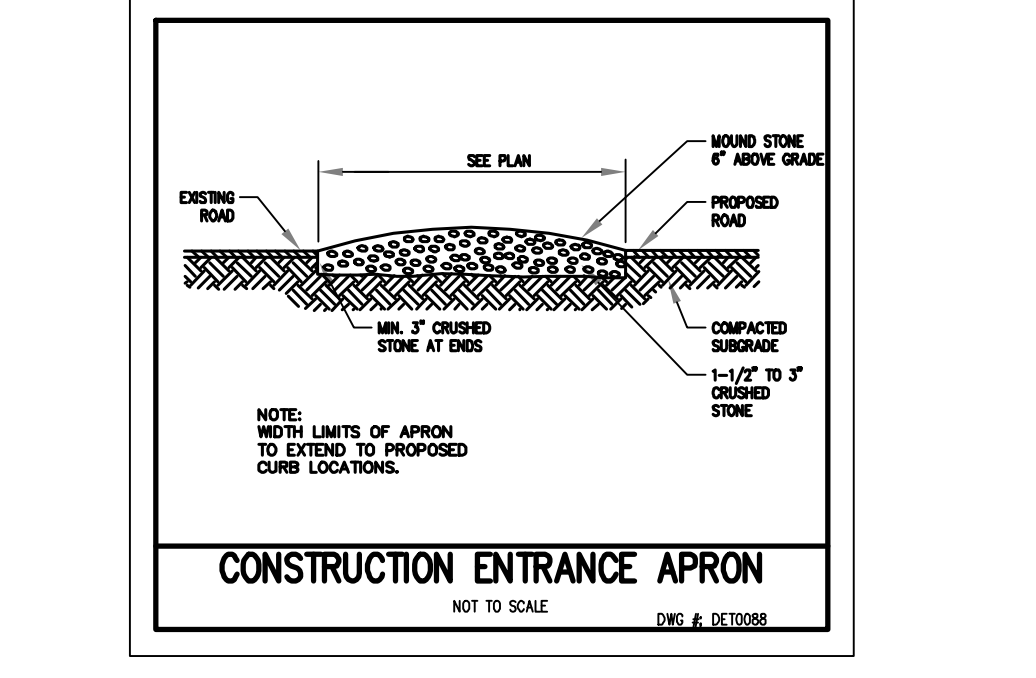
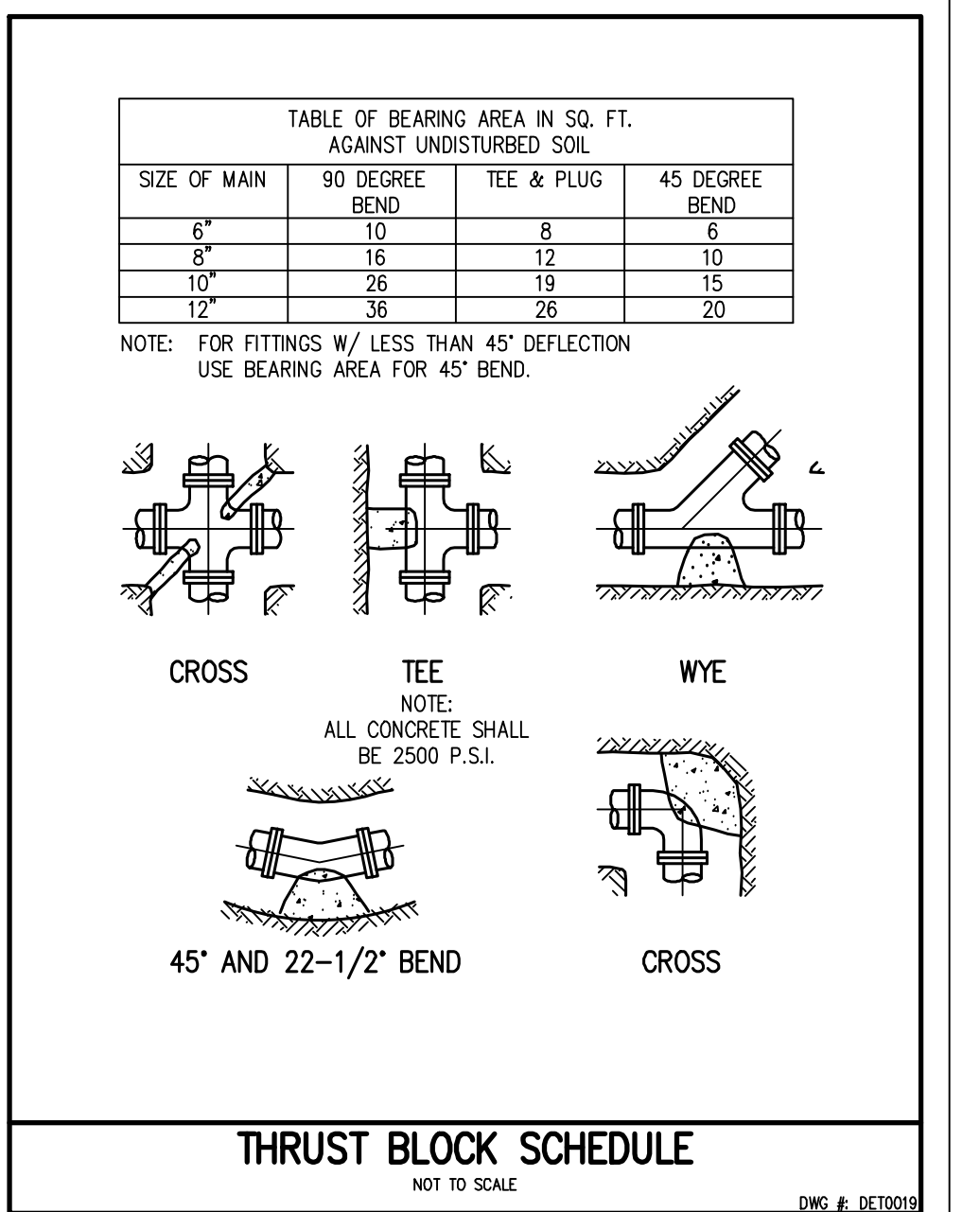
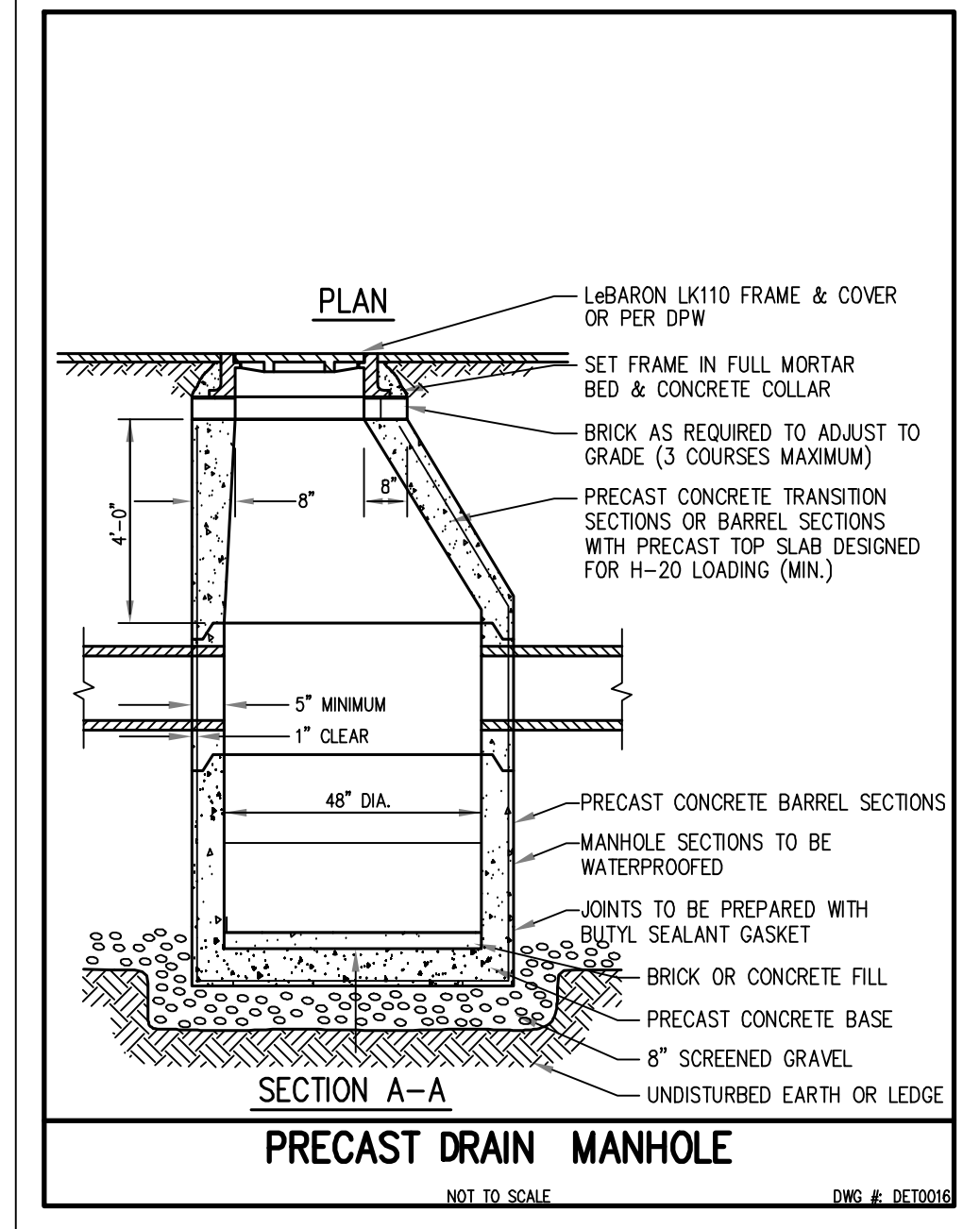
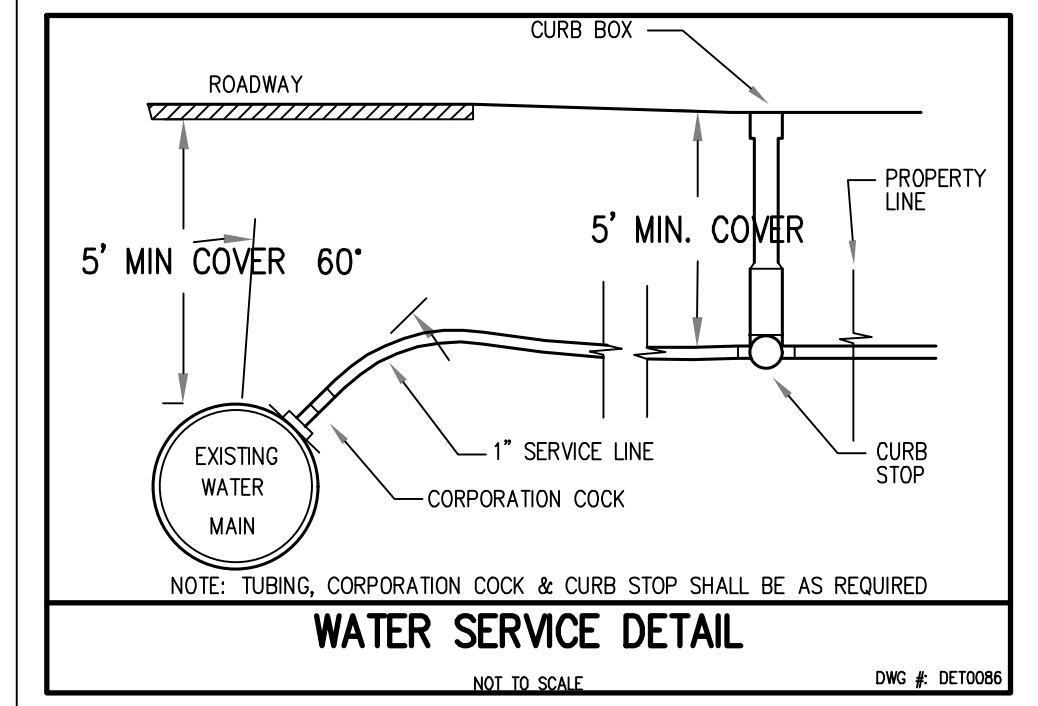
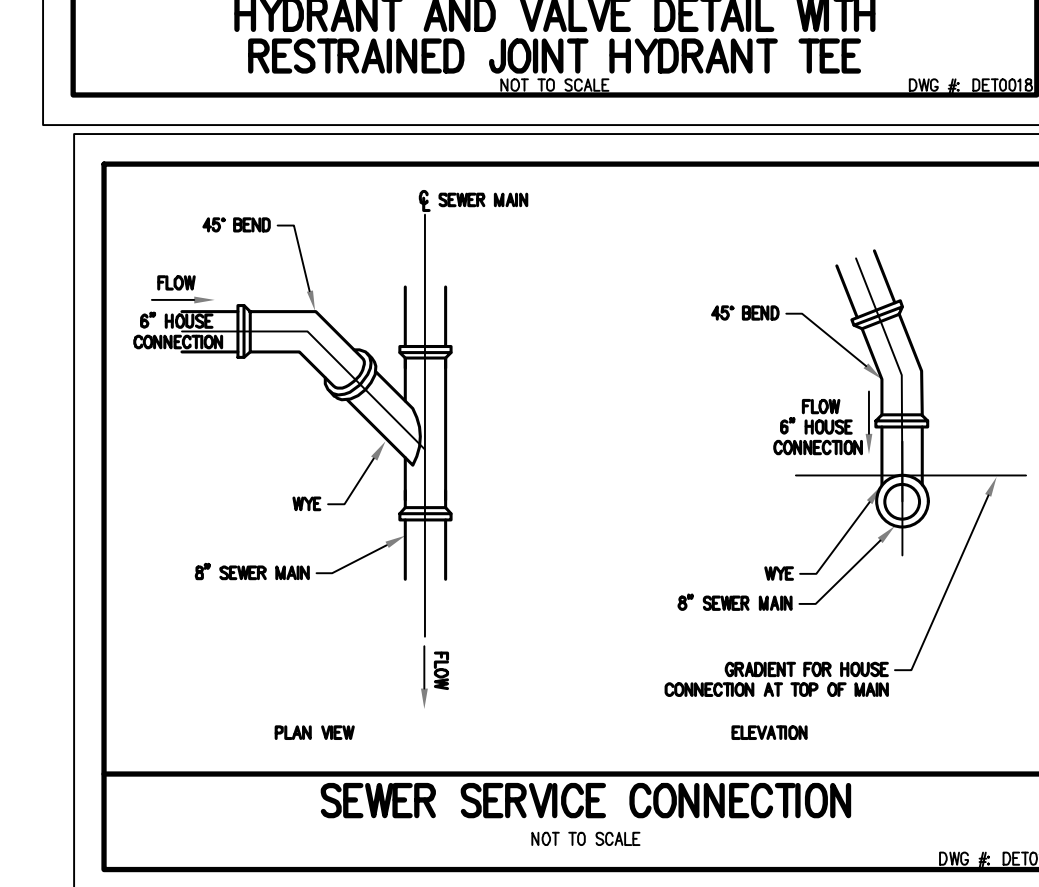
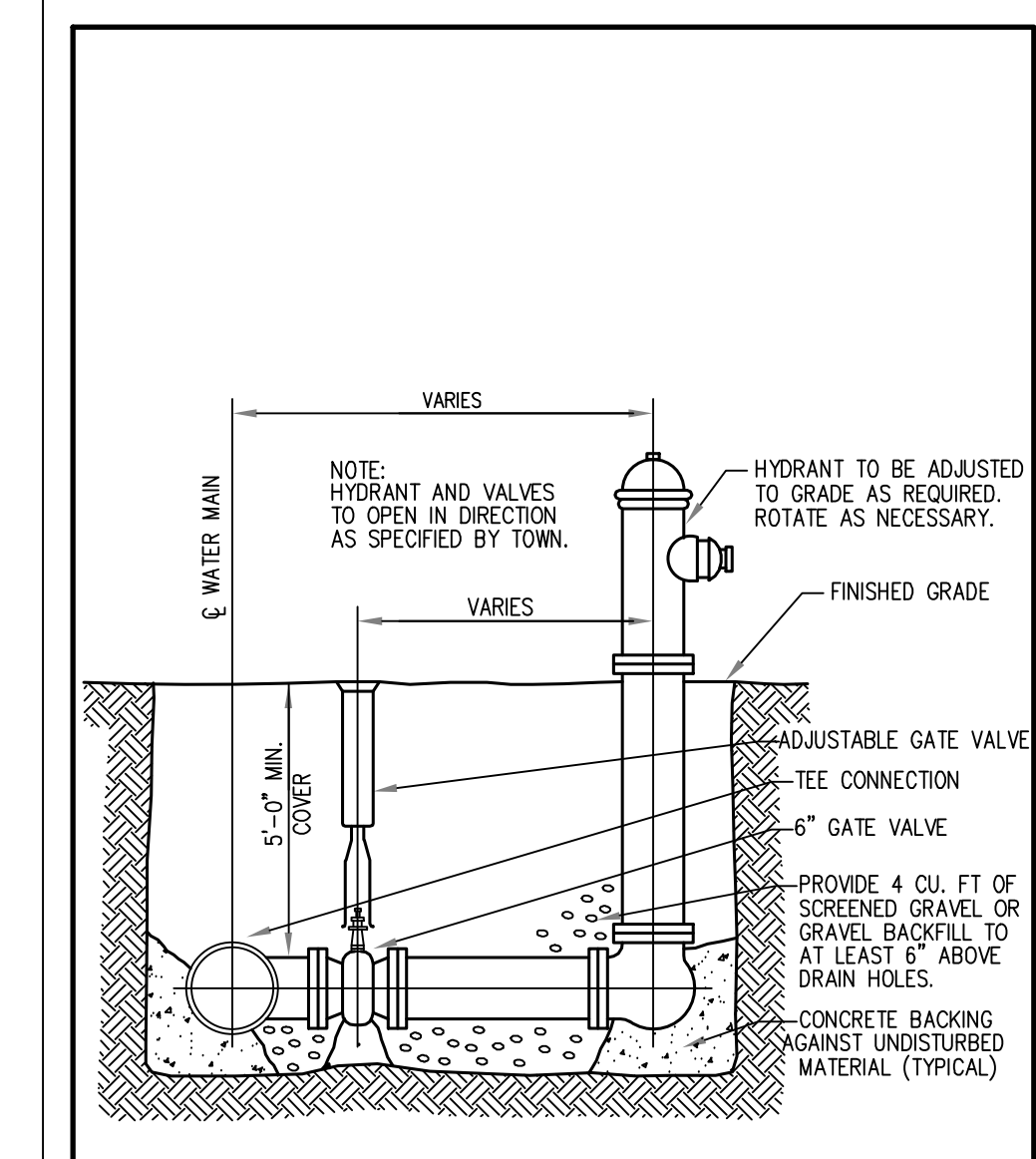
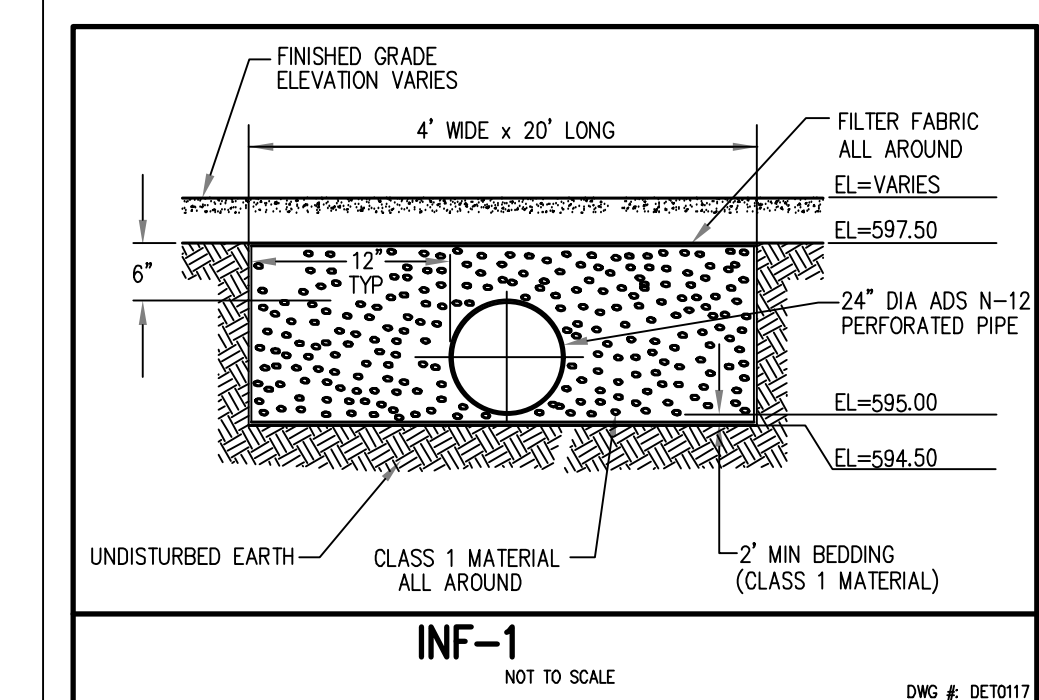
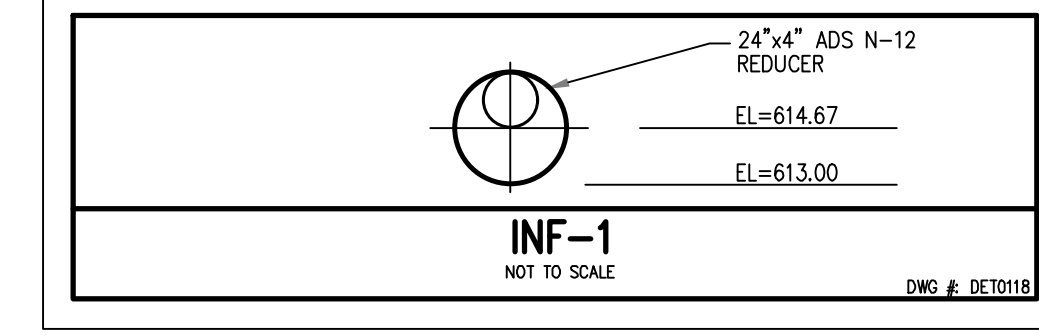
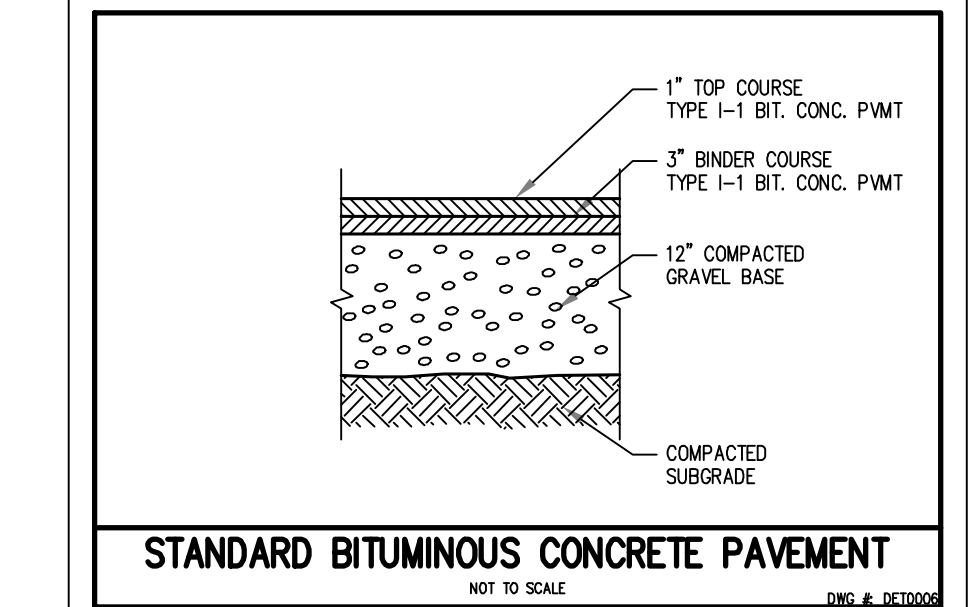
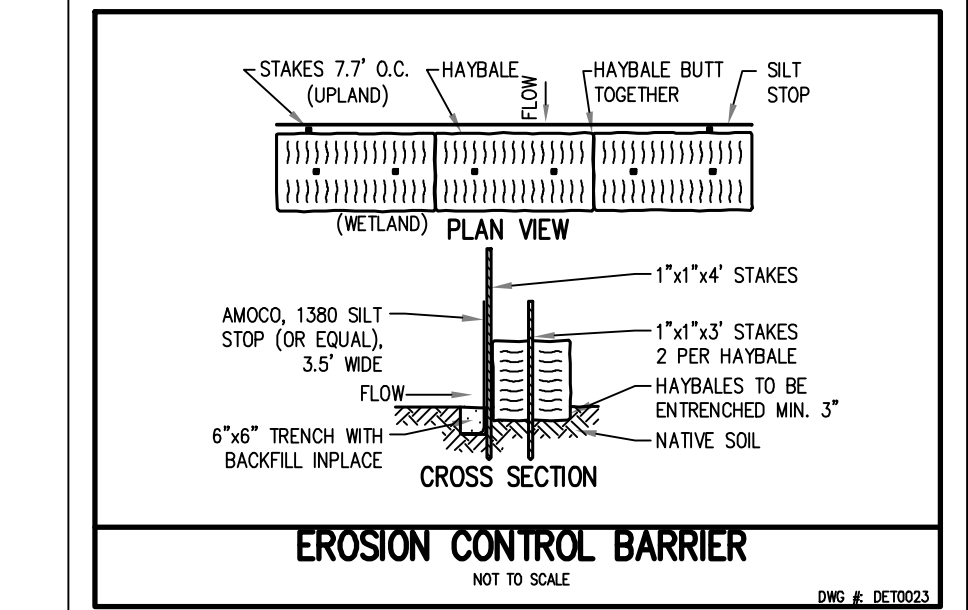
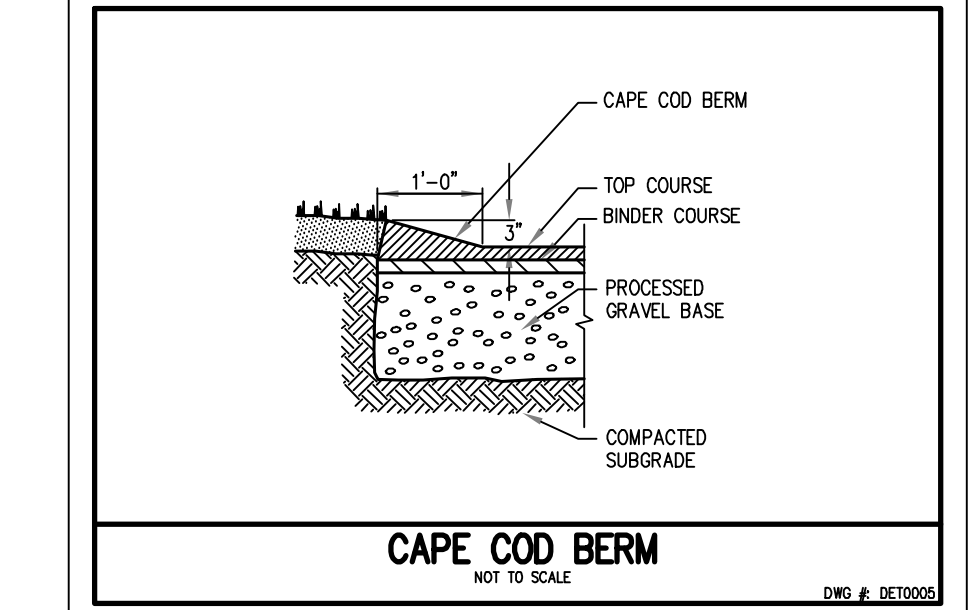
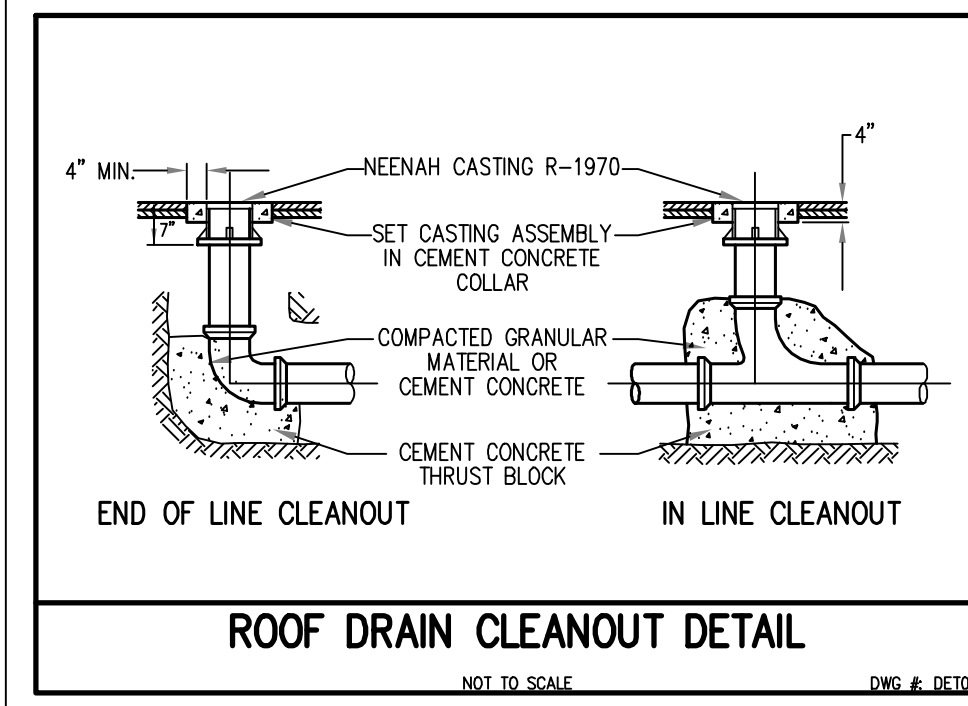
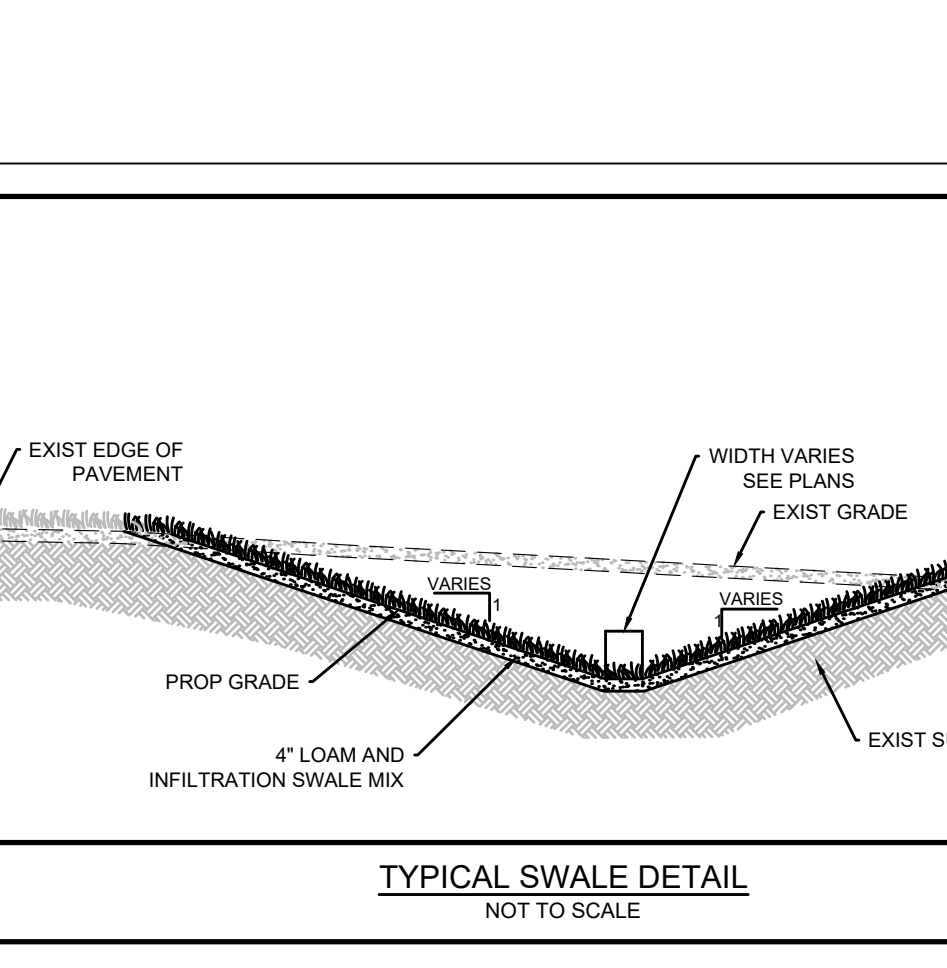
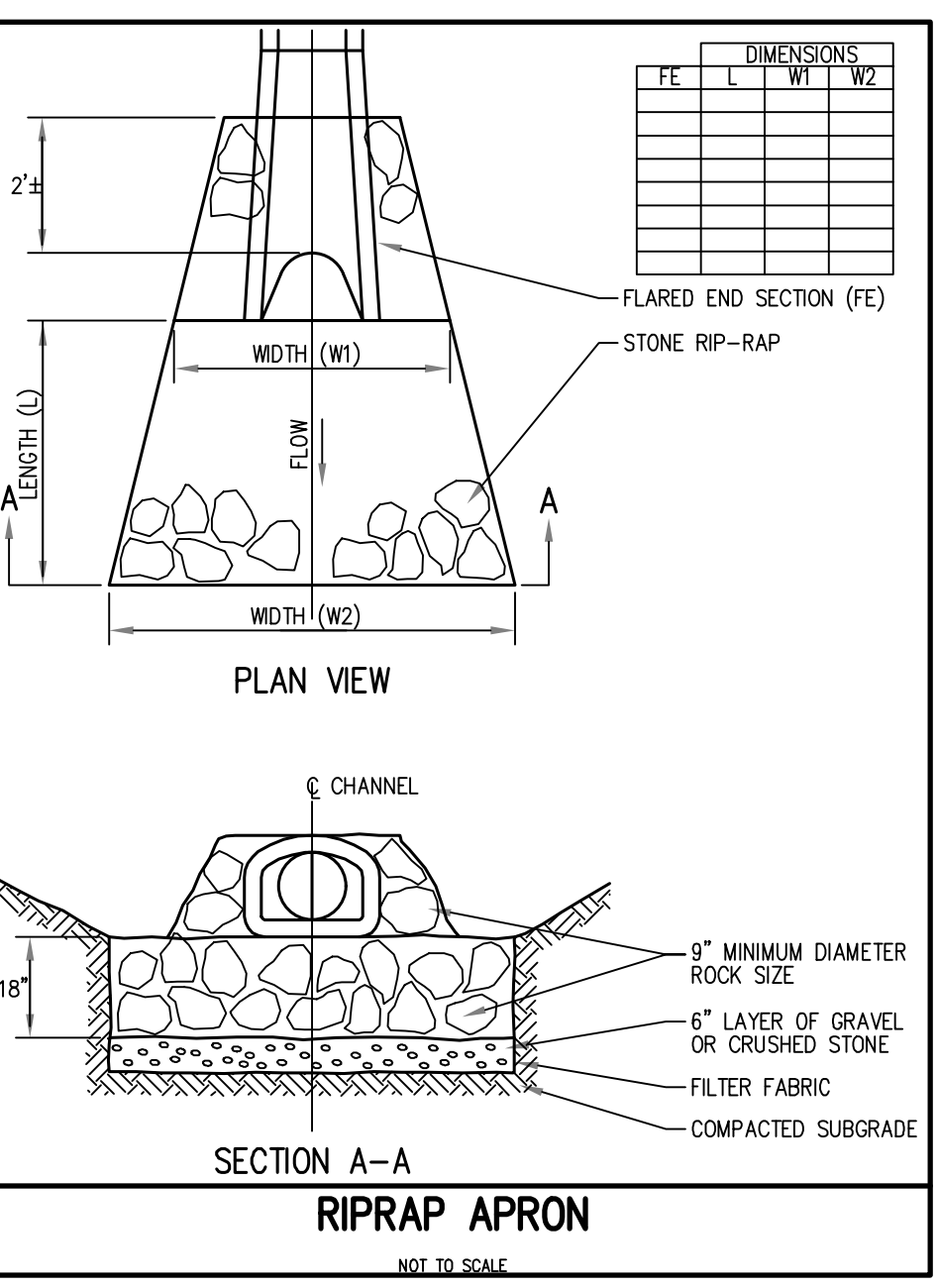
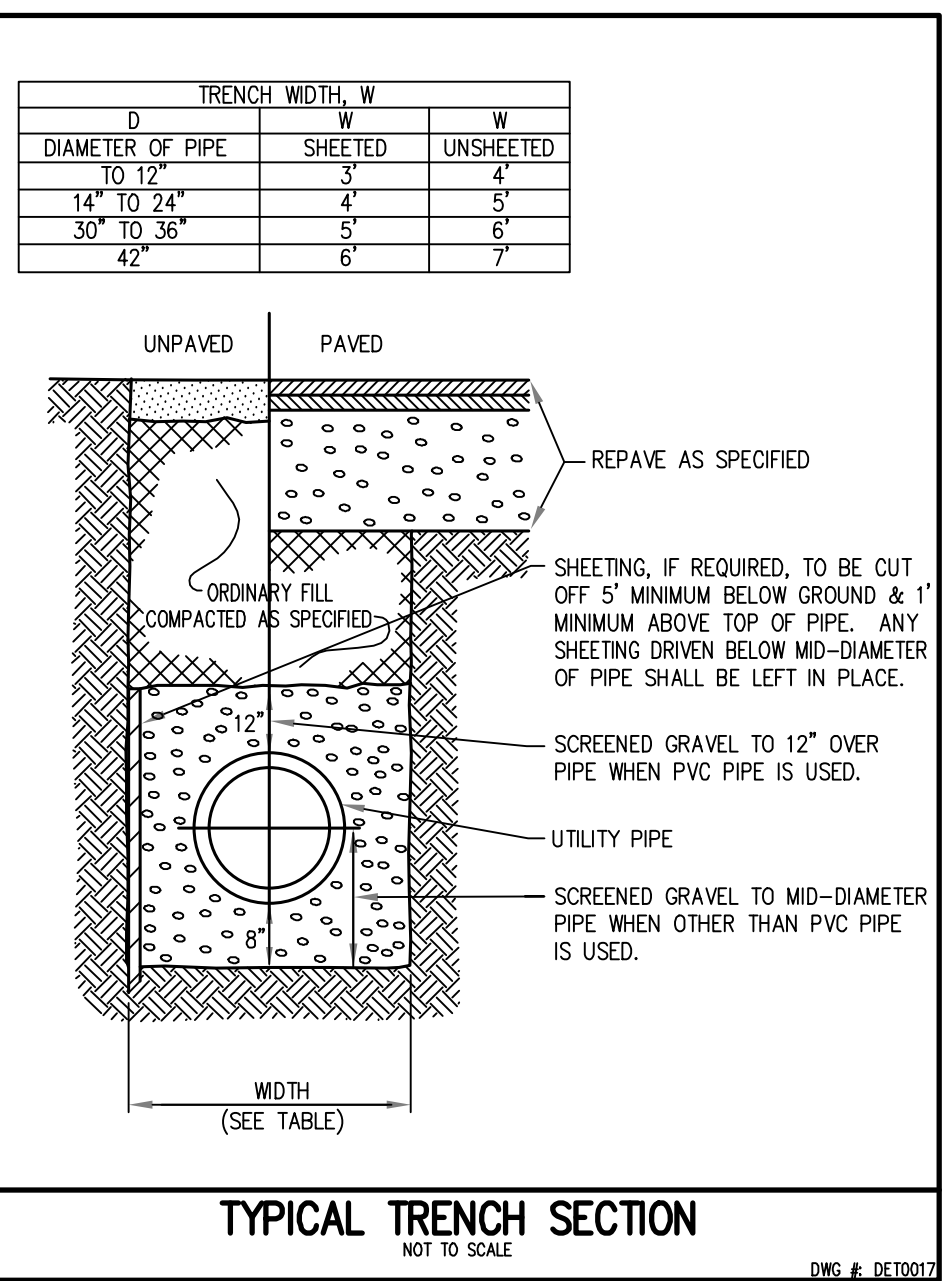

Project: 0 MEADOWBROOK
Date: 4/30/19
Scale: 1" = 20'
General Notes

No.	Revision/Issue	Date
---	EROS. CNTRL PLAN	4/30/19

Firm Name and Address:
Joseph Graham, PE
119 Pike St.
Tewksbury, MA 01876
(978) 501.2695

Project Name and Address:
SITE PLAN RECREATION
0 MEADOWBROOK
Worcester, MA 01607

Sheet: 5

General Information
(see reverse for instructions)

Name of Project	CGP Tracking No.	MAR12XXXX	Inspection Date
Inspector Name, Title & Contact Information			
Present Phase of Construction			
Inspection Location (if multiple inspections are required, specify location where this inspection is being conducted)			
Inspection Frequency Standard Frequency: <input checked="" type="checkbox"/> Weekly <input type="checkbox"/> Every 14 days and within 24 hours of a 0.25" rain			
Reduced Frequency: <ul style="list-style-type: none"> - <input type="checkbox"/> Once per month (for stabilized areas) - <input type="checkbox"/> Once per month and within 24 hours of a 0.25" rain (for arid, semi-arid, or drought-stricken areas during seasonally dry periods or during drought) - <input type="checkbox"/> Once per month (for frozen conditions where earth-disturbing activities are being conducted) 			
Was this inspection triggered by a 0.25" storm event? <input type="checkbox"/> Yes <input type="checkbox"/> No If yes, how did you determine whether a 0.25" storm event has occurred? <input type="checkbox"/> Rain gauge on site <input type="checkbox"/> Weather station representative of site. Specify weather station source: New Bedford Airport			
Total rainfall amount that triggered the inspection (in inches):			
Unsafe Conditions for Inspection Did you determine that any portion of your site was unsafe for inspection per CGP Part 4.1.5? <input type="checkbox"/> Yes <input type="checkbox"/> No If "yes", complete the following: - Describe the conditions that prevented you from conducting the inspection in this location:			
- Location(s) where conditions were found:			

Condition and Effectiveness of Erosion and Sediment (E&S) Controls (CGP Part 2.1)
(see reverse for instructions)

Type/Location of E&S Control [Add an additional sheet if necessary]	Repairs or Other Maintenance Needed?*	Corrective Action Required?*	Date on Which Maintenance or Corrective Action First Identified?	Notes
1.	<input type="checkbox"/> Yes <input type="checkbox"/> No	<input type="checkbox"/> Yes <input type="checkbox"/> No		
2.	<input type="checkbox"/> Yes <input type="checkbox"/> No	<input type="checkbox"/> Yes <input type="checkbox"/> No		
3.	<input type="checkbox"/> Yes <input type="checkbox"/> No	<input type="checkbox"/> Yes <input type="checkbox"/> No		
4.	<input type="checkbox"/> Yes <input type="checkbox"/> No	<input type="checkbox"/> Yes <input type="checkbox"/> No		
5.	<input type="checkbox"/> Yes <input type="checkbox"/> No	<input type="checkbox"/> Yes <input type="checkbox"/> No		
6.	<input type="checkbox"/> Yes <input type="checkbox"/> No	<input type="checkbox"/> Yes <input type="checkbox"/> No		
7.	<input type="checkbox"/> Yes <input type="checkbox"/> No	<input type="checkbox"/> Yes <input type="checkbox"/> No		
8.	<input type="checkbox"/> Yes <input type="checkbox"/> No	<input type="checkbox"/> Yes <input type="checkbox"/> No		
9.	<input type="checkbox"/> Yes <input type="checkbox"/> No	<input type="checkbox"/> Yes <input type="checkbox"/> No		
10.	<input type="checkbox"/> Yes <input type="checkbox"/> No	<input type="checkbox"/> Yes <input type="checkbox"/> No		

* Note: The permit differentiates between conditions requiring repairs and maintenance, and those requiring corrective action. The permit requires maintenance in order to keep controls in effective operating condition and requires repairs if controls are not operating as intended. Corrective actions are triggered only for specific, more serious conditions, which include: 1) A required stormwater control was never installed, was installed incorrectly, or not in accordance with the requirements in Part 2 and/or 3; 2) You become aware that the stormwater controls you have installed and are maintaining are not effective enough for the discharge to meet applicable water quality standards or applicable requirements in Part 3.1; 3) One of the prohibited discharges in Part 2.3.1 is occurring or has occurred; or 4) EPA requires corrective actions as a result of a permit violation found during an inspection carried out under Part 4.2. If a condition on your site requires a corrective action, you must also fill out a corrective action form found at www.epa.gov/npdes/stormwater/swppp, see Part 5 of the permit for more information.

Condition and Effectiveness of Pollution Prevention (P2) Practices (CGP Part 2.3)

(see reverse for instructions)

Type/Location of P2 Practices [Add an additional sheet if necessary]	Repairs or Other Maintenance Needed?*	Corrective Action Required?*	Date on Which Maintenance or Corrective Action First Identified?	Notes
1.	<input type="checkbox"/> Yes <input type="checkbox"/> No	<input type="checkbox"/> Yes <input type="checkbox"/> No		
2.	<input type="checkbox"/> Yes <input type="checkbox"/> No	<input type="checkbox"/> Yes <input type="checkbox"/> No		
3.	<input type="checkbox"/> Yes <input type="checkbox"/> No	<input type="checkbox"/> Yes <input type="checkbox"/> No		
4.	<input type="checkbox"/> Yes <input type="checkbox"/> No	<input type="checkbox"/> Yes <input type="checkbox"/> No		
5.	<input type="checkbox"/> Yes <input type="checkbox"/> No	<input type="checkbox"/> Yes <input type="checkbox"/> No		
6.	<input type="checkbox"/> Yes <input type="checkbox"/> No	<input type="checkbox"/> Yes <input type="checkbox"/> No		
7.	<input type="checkbox"/> Yes <input type="checkbox"/> No	<input type="checkbox"/> Yes <input type="checkbox"/> No		
8.	<input type="checkbox"/> Yes <input type="checkbox"/> No	<input type="checkbox"/> Yes <input type="checkbox"/> No		
9.	<input type="checkbox"/> Yes <input type="checkbox"/> No	<input type="checkbox"/> Yes <input type="checkbox"/> No		
10.	<input type="checkbox"/> Yes <input type="checkbox"/> No	<input type="checkbox"/> Yes <input type="checkbox"/> No		

* Note: The permit differentiates between conditions requiring repairs and maintenance, and those requiring corrective action. The permit requires maintenance in order to keep controls in effective operating condition and requires repairs if controls are not operating as intended. Corrective actions are triggered only for specific, more serious conditions, which include: 1) A required stormwater control was never installed, was installed incorrectly, or not in accordance with the requirements in Part 2 and/or 3; 2) You become aware that the stormwater controls you have installed and are maintaining are not effective enough for the discharge to meet applicable water quality standards or applicable requirements in Part 3.1; 3) One of the prohibited discharges in Part 2.3.1 is occurring or has occurred; or 4) EPA requires corrective actions as a result of a permit violation found during an inspection carried out under Part 4.2. If a condition on your site requires a corrective action, you must also fill out a corrective action form found at www.epa.gov/hqdes/stormwater/swppp. See Part 5 of the permit for more information.

Stabilization of Exposed Soil (CGP Part 2.2)

(see reverse for instructions)

Stabilization Area [Add an additional sheet if necessary]	Stabilization Method	Have You Initiated Stabilization?	Notes
1.		<input type="checkbox"/> YES <input type="checkbox"/> NO If yes, provide date:	
2.		<input type="checkbox"/> YES <input type="checkbox"/> NO If yes, provide date:	
3.		<input type="checkbox"/> YES <input type="checkbox"/> NO If yes, provide date:	
4.		<input type="checkbox"/> YES <input type="checkbox"/> NO If yes, provide date:	
5.		<input type="checkbox"/> YES <input type="checkbox"/> NO If yes, provide date:	

Description of Discharges (CGP Part 4.1.6.6)

(see reverse for instructions)

Was a stormwater discharge or other discharge occurring from any part of your site at the time of the inspection? <input type="checkbox"/> Yes <input type="checkbox"/> No	
If "yes", provide the following information for each point of discharge:	
Discharge Location [Add an additional sheet if necessary]	Observations
1.	Describe the discharge: At points of discharge and the channels and banks of surface waters in the immediate vicinity, are there any visible signs of erosion and/or sediment accumulation that can be attributed to your discharge? <input type="checkbox"/> Yes <input type="checkbox"/> No If yes, describe what you see, specify the location(s) where these conditions were found, and indicate whether modification, maintenance, or corrective action is needed to resolve the issue:
2.	Describe the discharge: At points of discharge and the channels and banks of surface waters in the immediate vicinity, are there any visible signs of erosion and/or sediment accumulation that can be attributed to your discharge? <input type="checkbox"/> Yes <input type="checkbox"/> No If yes, describe what you see, specify the location(s) where these conditions were found, and indicate whether modification, maintenance, or corrective action is needed to resolve the issue:

Contractor or Subcontractor Certification and Signature

(see reverse for instructions)

"I certify under penalty of law that this document and all attachments were prepared under my direction or supervision in accordance with a system designed to assure that qualified personnel properly gathered and evaluated the information submitted. Based on my inquiry of the person or persons who manage the system, or those persons directly responsible for gathering the information, the information submitted is, to the best of my knowledge and belief, true, accurate, and complete. I am aware that there are significant penalties for submitting false information, including the possibility of fine and imprisonment for knowing violations."

Signature of Contractor or Subcontractor: _____ Date: _____

Printed Name and Affiliation: _____

Certification and Signature by Permittee

(see reverse for instructions)

"I certify under penalty of law that this document and all attachments were prepared under my direction or supervision in accordance with a system designed to assure that qualified personnel properly gathered and evaluated the information submitted. Based on my inquiry of the person or persons who manage the system, or those persons directly responsible for gathering the information, the information submitted is, to the best of my knowledge and belief, true, accurate, and complete. I am aware that there are significant penalties for submitting false information, including the possibility of fine and imprisonment for knowing violations."

Signature of Permittee or "Duly Authorized Representative": _____ Date: _____

Printed Name and Affiliation: _____

Section C – Certification and Signature (CGP Part 5.4.3)

Section C.1 – Certification and Signature by Contractor or Subcontractor

"I certify under penalty of law that this document and all attachments were prepared under my direction or supervision in accordance with a system designed to assure that qualified personnel properly gathered and evaluated the information submitted. Based on my inquiry of the person or persons who manage the system, or those persons directly responsible for gathering the information, the information submitted is, to the best of my knowledge and belief, true, accurate, and complete. I am aware that there are significant penalties for submitting false information, including the possibility of fine and imprisonment for knowing violations."

Signature of Contractor or Subcontractor: _____ **Date:** _____

Printed Name and Affiliation: _____

Section C.2 – Certification and Signature by Permittee

"I certify under penalty of law that this document and all attachments were prepared under my direction or supervision in accordance with a system designed to assure that qualified personnel properly gathered and evaluated the information submitted. Based on my inquiry of the person or persons who manage the system, or those persons directly responsible for gathering the information, the information submitted is, to the best of my knowledge and belief, true, accurate, and complete. I am aware that there are significant penalties for submitting false information, including the possibility of fine and imprisonment for knowing violations."

**Signature of Permittee or
"Duly Authorized Representative":** _____ **Date:** _____

Printed Name and Affiliation: _____

